

**Friday 17 June 2016 – Morning**

**GCSE TWENTY FIRST CENTURY SCIENCE  
PHYSICS A/ADDITIONAL SCIENCE A**

**A182/01** Modules P4 P5 P6 (Foundation Tier)

Candidates answer on the Question Paper.  
A calculator may be used for this paper.

**OCR supplied materials:**  
None

**Other materials required:**

- Pencil
- Ruler (cm/mm)

**Duration:** 1 hour

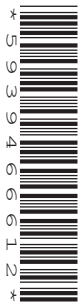

Candidate forename		Candidate surname	
-----------------------	--	----------------------	--

Centre number						Candidate number				
---------------	--	--	--	--	--	------------------	--	--	--	--

### INSTRUCTIONS TO CANDIDATES

- Write your name, centre number and candidate number in the boxes above. Please write clearly and in capital letters.
- Use black ink. HB pencil may be used for graphs and diagrams only.
- Answer **all** the questions.
- Read each question carefully. Make sure you know what you have to do before starting your answer.
- Write your answer to each question in the space provided. If additional space is required, you should use the lined page(s) at the end of this booklet. The question number(s) must be clearly shown.
- Do **not** write in the bar codes.

### INFORMATION FOR CANDIDATES

- The quality of written communication is assessed in questions marked with a pencil (✎).
- A list of useful relationships is printed on page 2.
- The number of marks is given in brackets [ ] at the end of each question or part question.
- The total number of marks for this paper is **60**.
- This document consists of **24** pages. Any blank pages are indicated.

## TWENTY FIRST CENTURY SCIENCE EQUATIONS

### Useful relationships

#### The Earth in the Universe

$$\text{distance} = \text{wave speed} \times \text{time}$$

$$\text{wave speed} = \text{frequency} \times \text{wavelength}$$

#### Sustainable energy

$$\text{energy transferred} = \text{power} \times \text{time}$$

$$\text{power} = \text{voltage} \times \text{current}$$

$$\text{efficiency} = \frac{\text{energy usefully transferred}}{\text{total energy supplied}} \times 100\%$$

#### Explaining motion

$$\text{speed} = \frac{\text{distance travelled}}{\text{time taken}}$$

$$\text{acceleration} = \frac{\text{change in velocity}}{\text{time taken}}$$

$$\text{momentum} = \text{mass} \times \text{velocity}$$

$$\text{change of momentum} = \text{resultant force} \times \text{time for which it acts}$$

$$\text{work done by a force} = \text{force} \times \text{distance moved in the direction of the force}$$

$$\text{amount of energy transferred} = \text{work done}$$

$$\text{change in gravitational potential energy} = \text{weight} \times \text{vertical height difference}$$

$$\text{kinetic energy} = \frac{1}{2} \times \text{mass} \times [\text{velocity}]^2$$

#### Electric circuits

$$\text{power} = \text{voltage} \times \text{current}$$

$$\text{resistance} = \frac{\text{voltage}}{\text{current}}$$

$$\frac{\text{voltage across primary coil}}{\text{voltage across secondary coil}} = \frac{\text{number of turns in primary coil}}{\text{number of turns in secondary coil}}$$

#### Radioactive materials

$$\text{energy} = \text{mass} \times [\text{speed of light in a vacuum}]^2$$

**BLANK PAGE**

**Question 1 begins on page 4**

**PLEASE DO NOT WRITE ON THIS PAGE**

Answer **all** the questions

1 Beth is doing some experiments with electricity.

(a) She rubs a plastic rod with a cloth.

The rod becomes negatively charged.

Which statement explains how the rod gains the negative charge?

Put a tick (✓) in the box next to the correct answer.

Electrons move from the cloth on to the rod.

Electrons move from the rod on to the cloth.

Molecules move from the cloth on to the rod.

Molecules move from the rod on to the cloth.

[1]

(b) Beth brings the negatively charged rod towards another rod that is hung from a string.

The rods **repel** each other.

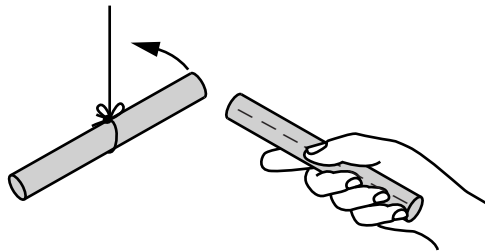

(i) What is the charge on the rod that is hung from the string?

Draw **one** straight line from the correct **charge** to the **explanation**.

**Charge**

**Explanation**

negative

like charges repel

neutral

unlike charges attract

positive

[1]

- (ii) Beth thinks the charge on the rod she is holding will leak away because the rod is a conductor.

Is Beth correct?  
Justify your answer.

.....

.....

..... [2]

[Total: 4]

- 2 In another experiment Beth sets up a wire between the poles of a magnet.

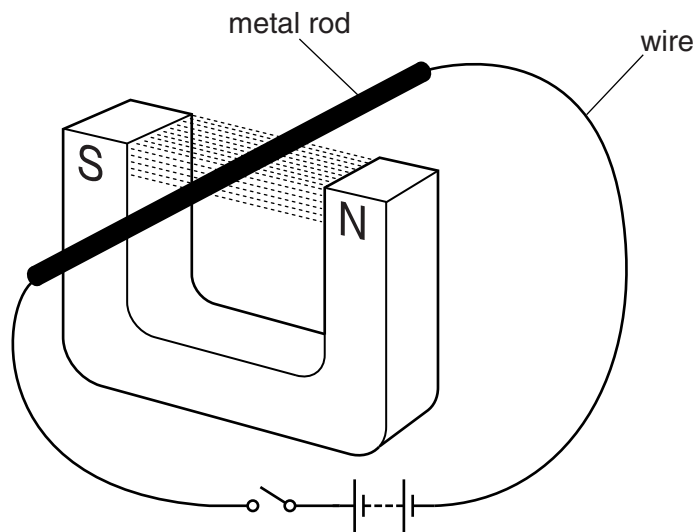

- (a) When she closes the switch the metal rod experiences a force.

**On the diagram** draw an arrow to show the direction of this force.

[1]

- (b) State **one** change Beth can make so that the force is in the opposite direction.

..... [1]

- (c) Which device below makes use of the effect described in (a)?

Put a tick (✓) in the box next to the correct device.

motor	<input type="checkbox"/>
lamp	<input type="checkbox"/>
kettle	<input type="checkbox"/>
thermometer	<input type="checkbox"/>

[1]

[Total: 3]

**BLANK PAGE**

**Question 3 begins on page 8**

**PLEASE DO NOT WRITE ON THIS PAGE**

3 This question is about electric lamps.

(a) The table gives information about different types of lamps.

The information is stated on the lamp and refers to its normal operating conditions.

Type of lamp	Information
fluorescent	230V, 8W
spiral	110V, 11W
filament	3V, 2W
LED	1.5V, 1W

(i) Which lamp uses most electrical energy every second when operating normally?  
Put a **ring** around the correct answer.

**fluorescent**      **spiral**      **filament**      **LED**      [1]

(ii) Which lamp is designed to be connected to the mains supply in a house in the UK?  
Put a **ring** around the correct answer.

**fluorescent**      **spiral**      **filament**      **LED**      [1]

(iii) The filament lamp can be powered by cells.

How many 1.5V cells need to be connected in series so the lamp lights normally?

Put a **ring** around the correct answer.

**one**      **two**      **three**      **four**      [1]



(b) Jason is investigating how the resistance of a filament lamp changes with the current through it.

He connects the lamp to a power supply and a variable resistor.

He uses an ammeter to measure the current through the lamp and a voltmeter to measure the voltage across it.

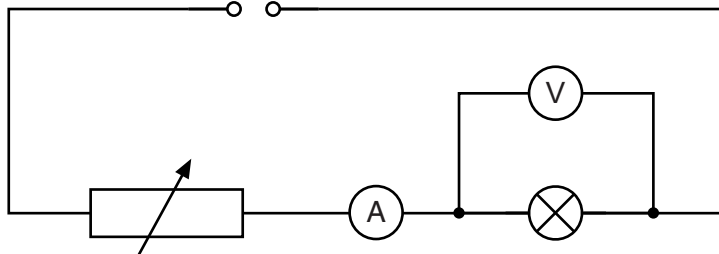

(i) On the diagram put a ring around the symbol for the ammeter. [1]

(ii) These are Jason's results.

<b>Voltage (V)</b>	1.0	3.0
<b>Current (A)</b>	0.10	0.20

How does the resistance of the lamp change as the current increases?  
Justify your conclusion by doing calculations with Jason's results.

.....  
 ..... [3]

(iii) Suggest what Jason can do to ensure his results are accurate.  
 .....  
 ..... [1]

[Total: 8]



5 Radioactive materials are used in hospitals.

Radioactive tracers allow the doctor to investigate organs in a patient’s body without surgery.

The radioactive tracer can be injected into a patient’s vein.

(a) The doctor has this information about the activity from three radioactive tracers that emit gamma rays.

Tracer	Activity (counts per minute)		
	At start	After 1 hour	After 2 hours
A	1000	700	500
B	1000	500	250
C	1000	250	60

The doctor wants to use a tracer with a half-life of 1 hour.

Which tracer should the doctor choose?  
Justify your choice.

.....

.....

..... [2]

(b) The doctor wants Sally to be investigated using this radioactive tracer. Sally is anxious about this. She knows that gamma rays can cause cancer.

Suggest what the doctor might say to Sally to reassure her.

.....

.....

.....

..... [3]

[Total: 5]

6 Kal lives near to a site where it is proposed to build a new nuclear power station.

(a) Which process describes how energy is released from the nuclear fuel in the power station?

Put a tick (✓) in the box next to the correct answer.

- burning
- changes in the nucleus
- chemical reaction
- ionisation

[1]

(b) Nuclear power stations produce waste.

Kal is concerned because he has heard about the dangers of such waste materials.

The waste is categorised as high level, intermediate level and low level.

(i) High level waste is

- stored in water for many years
- then sealed in steel canisters
- then buried deep underground.

Explain the reasons for this method of disposal.

.....

.....

.....

.....

.....

.....

..... [3]

(ii) Low level waste is put in landfills.

Give **one** reason why low level waste does not need the same disposal method as high level waste.

.....

..... [1]

(c) Kal discusses his concerns with his friend Mary.

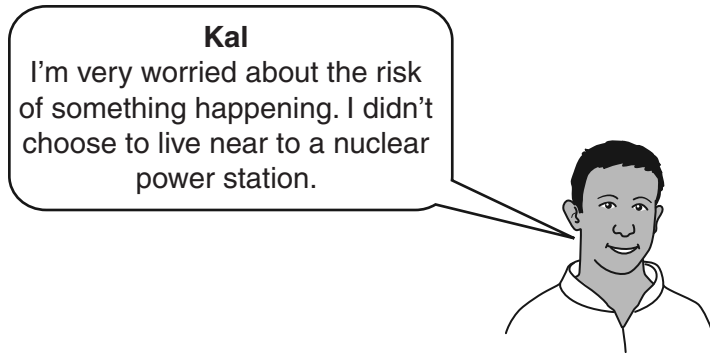

Suggest some ideas that Mary could use to reassure Kal.

.....

.....

.....

.....

..... [3]

[Total: 8]



**15**  
**BLANK PAGE**

**Question 8 begins on page 16**  
**PLEASE DO NOT WRITE ON THIS PAGE**

8 Lorries are fitted with tachometers that automatically record their speed and distance travelled.

The data from the tachometer is used to produce graphs.

(a) This graph shows the distance-time graph for part of a journey.

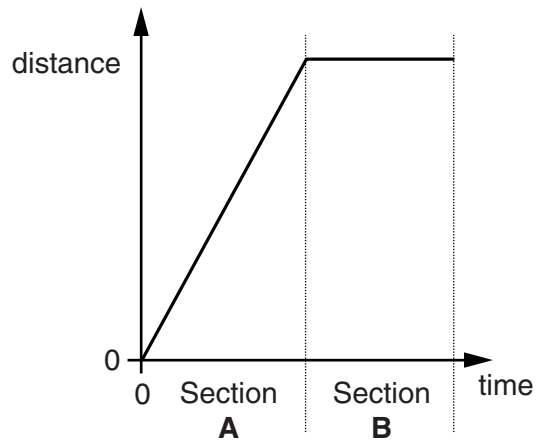

How is the lorry moving during sections **A** and **B** of its journey?

Draw one straight line from each **section** to its correct **motion**.

**Section**

**Motion**

**A**

**B**

moving at constant speed

slowing down

speeding up

not moving

[2]



(b) This graph shows the **speed-time** graph for part of another journey.

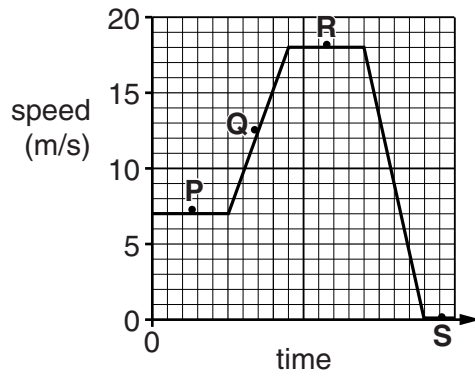

(i) What is the maximum speed of the lorry shown on the graph?

maximum speed = ..... m/s [1]

(ii) At which point on the graph is the lorry not moving?  
Put a ring around the correct answer.

P            Q            R            S

[1]

(c) The diagram shows the four forces acting on the lorry as it moves at constant speed along a straight, horizontal road.

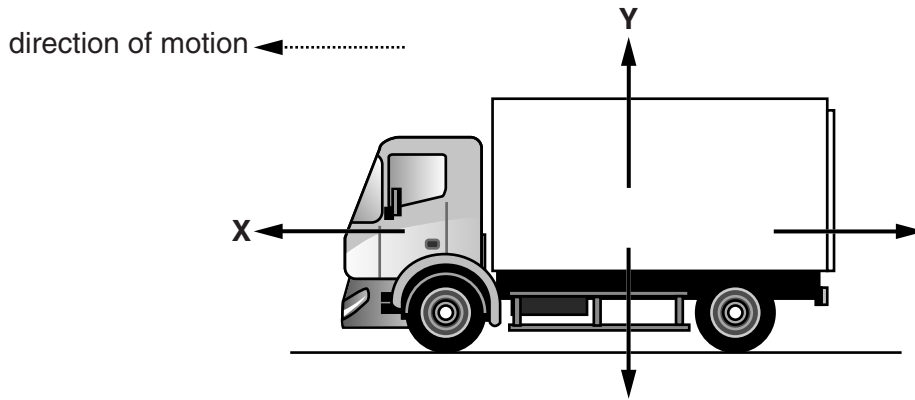

(i) What are the names of the forces labelled **X** and **Y** on the diagram?

Draw one straight line from each **force** to its correct **name**.

Force	Name
	counter force
<b>X</b>	driving force
<b>Y</b>	reaction
	weight

[2]

(ii) The lorry is moving at constant speed.

Explain how this is shown by the two horizontal arrows on the diagram.

.....

.....

..... [2]

[Total: 8]



10 Roy is stacking shelves at the supermarket.

He lifts boxes of tins from the floor to the shelves.

(a) Each tin weighs 5 N.

An empty box weighs 2 N.

(i) What is the smallest force that Roy has to pull on a **box of 4 tins** when lifting it?

force = ..... N [1]

(ii) Roy lifts a box of 4 tins from the floor to a shelf 0.5 m above the floor.

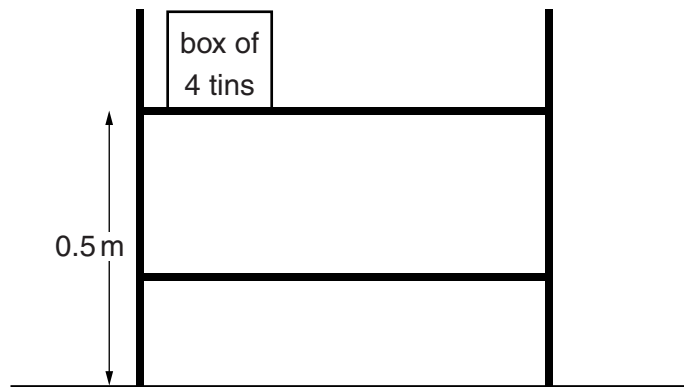

Calculate how much gravitational potential energy the box gains.  
Include the correct unit in your answer.

gain in gravitational potential energy = ..... unit ..... [2]

(iii)

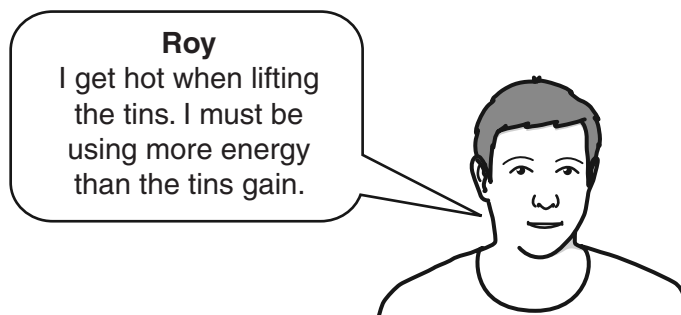

State what is meant by **conservation of energy** and explain how it applies to Roy.

.....

.....

.....

..... [2]

(b) Roy lifts boxes of 4 tins and boxes of 6 tins from the floor onto the shelves.

He puts a box of 4 tins and a box of 6 tins on each shelf, as shown in the diagram.

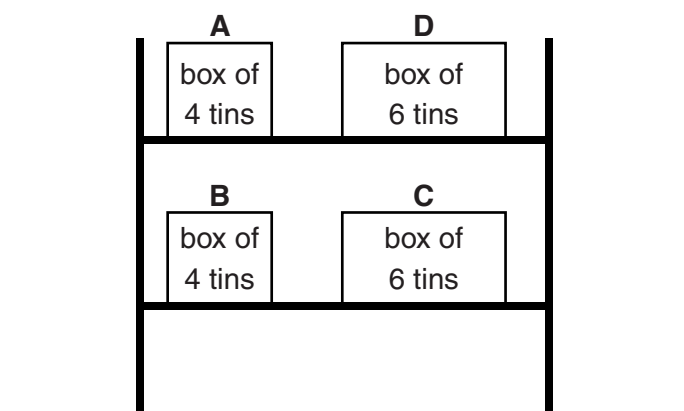

Which box gains the most gravitational potential energy?  
Put a ring around the correct answer.

**A      B      C      D**

[1]

[Total: 6]

**END OF QUESTION PAPER**

**ADDITIONAL ANSWER SPACE**

If additional space is required, you should use the following lined page(s). The question number(s) must be clearly shown in the margin(s).

A large area of lined paper for writing. It consists of a vertical solid line on the left side, creating a margin. To the right of this line, there are numerous horizontal dotted lines spaced evenly down the page, providing a guide for handwriting.

A large rectangular area with a solid vertical line on the left side and horizontal dotted lines extending across the page, resembling a ledger or a writing template.

A large area of the page is reserved for writing, featuring a vertical margin line on the left and horizontal dotted lines for ruling.



**Copyright Information**

OCR is committed to seeking permission to reproduce all third-party content that it uses in its assessment materials. OCR has attempted to identify and contact all copyright holders whose work is used in this paper. To avoid the issue of disclosure of answer-related information to candidates, all copyright acknowledgements are reproduced in the OCR Copyright Acknowledgements Booklet. This is produced for each series of examinations and is freely available to download from our public website ([www.ocr.org.uk](http://www.ocr.org.uk)) after the live examination series.

If OCR has unwittingly failed to correctly acknowledge or clear any third-party content in this assessment material, OCR will be happy to correct its mistake at the earliest possible opportunity.

For queries or further information please contact the Copyright Team, First Floor, 9 Hills Road, Cambridge CB2 1GE.

OCR is part of the Cambridge Assessment Group; Cambridge Assessment is the brand name of University of Cambridge Local Examinations Syndicate (UCLES), which is itself a department of the University of Cambridge.