

Write your name here	
Surname	Other names
Centre Number	Candidate Number
<input type="text"/>	<input type="text"/>
Edexcel GCSE	
Mathematics B	
Unit 2: Number, Algebra, Geometry 1	
(Non-Calculator)	
Higher Tier	
Friday 12 November 2010 – Morning	Paper Reference
Time: 1 hour 15 minutes	5MB2H/01
You must have: Ruler graduated in centimetres and millimetres, protractor, compasses, pen, HB pencil, eraser. Tracing paper may be used.	Total Marks
	<input type="text"/>

Instructions

- Use **black** ink or ball-point pen.
- **Fill in the boxes** at the top of this page with your name, centre number and candidate number.
- Answer **all** questions.
- Answer the questions in the spaces provided
– *there may be more space than you need.*
- **Calculators must not be used.**



Information

- The total mark for this paper is 60.
- The marks for **each** question are shown in brackets
– *use this as a guide as to how much time to spend on each question.*
- Questions labelled with an **asterisk** (*) are ones where the quality of your written communication will be assessed
– *you should take particular care on these questions with your spelling, punctuation and grammar, as well as the clarity of expression.*

Advice

- Read each question carefully before you start to answer it.
- Keep an eye on the time.
- Try to answer every question.
- Check your answers if you have time at the end.

Turn over ►

N38396A

©2010 Edexcel Limited.
6/6/6/6/e2



edexcel 
advancing learning, changing lives

GCSE Mathematics 2MB01

Formulae – Higher Tier

**You must not write on this formulae page.
Anything you write on this formulae page will gain NO credit.**

Volume of a prism = area of cross section \times length

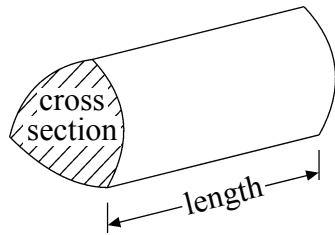

Area of trapezium = $\frac{1}{2}(a+b)h$

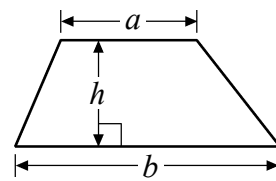

Volume of sphere = $\frac{4}{3}\pi r^3$

Surface area of sphere = $4\pi r^2$

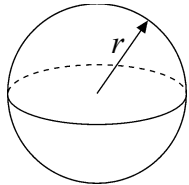

Volume of cone = $\frac{1}{3}\pi r^2 h$

Curved surface area of cone = $\pi r l$

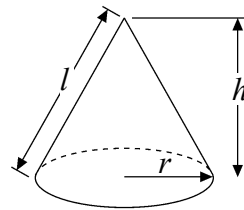

In any triangle ABC

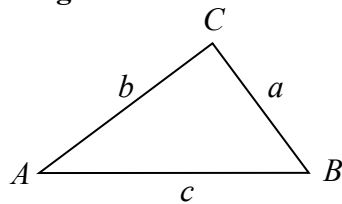

The Quadratic Equation

The solutions of $ax^2 + bx + c = 0$

where $a \neq 0$, are given by

$$x = \frac{-b \pm \sqrt{b^2 - 4ac}}{2a}$$

Sine Rule $\frac{a}{\sin A} = \frac{b}{\sin B} = \frac{c}{\sin C}$

Cosine Rule $a^2 = b^2 + c^2 - 2bc \cos A$

Area of triangle = $\frac{1}{2}ab \sin C$



Answer ALL questions.

Write your answers in the spaces provided.

You must write down all stages in your working.

1 Grace and Jack share £140 in the ratio 3 : 4

Work out the amount of money that Jack gets.

£

(Total for Question 1 is 2 marks)

2 (a) Simplify $4b \times 2c$

.....
(1)

(b) Expand $3(2w - 5t)$

.....
(2)

(c) Expand and simplify $(x + 7)(x - 2)$

.....
(2)

(Total for Question 2 is 5 marks)



3 Work out 15% of £80

£

(Total for Question 3 is 2 marks)

4

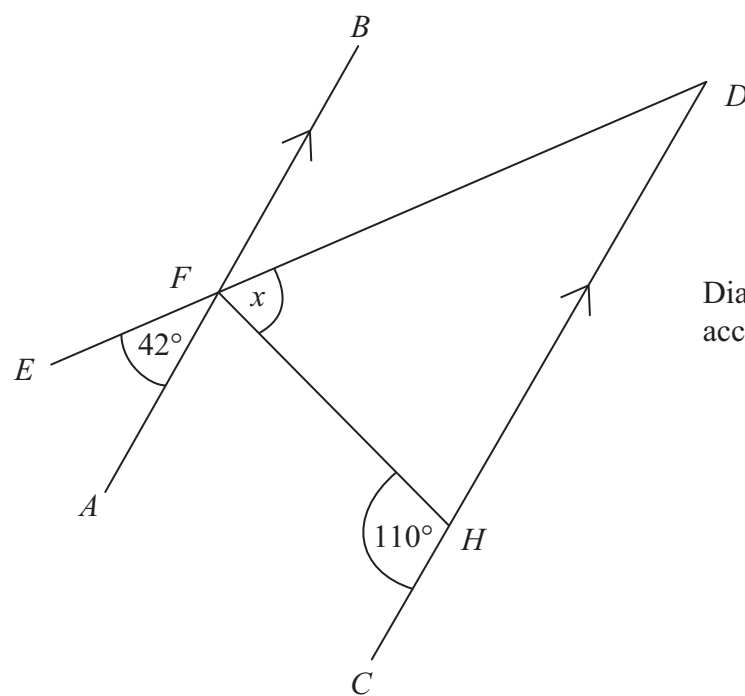

Diagram **NOT**
accurately drawn

AFB and *CHD* are parallel lines.
EFD is a straight line.

Work out the size of the angle marked *x*.

$x = \dots\dots\dots^\circ$

(Total for Question 4 is 3 marks)



5 Find the Lowest Common Multiple (LCM) of 8 and 12

.....
(Total for Question 5 is 2 marks)

6 The diagram shows 3 sides of a regular polygon.

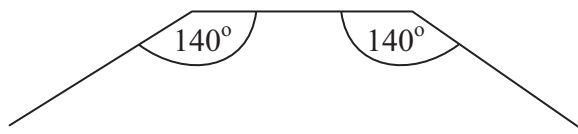

Diagram **NOT** accurately drawn

Each interior angle of the regular polygon is 140° .

Work out the number of sides of the regular polygon.

.....
(Total for Question 6 is 3 marks)



7 You can use this formula to change a temperature C , in $^{\circ}\text{C}$, to a temperature F , in $^{\circ}\text{F}$.

$$F = 1.8C + 32$$

(a) Use the formula to change 20°C into $^{\circ}\text{F}$.

..... $^{\circ}\text{F}$
(2)

(b) On the grid opposite, draw a conversion graph that can be used to change between temperatures in $^{\circ}\text{C}$ and temperatures in $^{\circ}\text{F}$.

(3)

(c) Use your graph to change 100°F into $^{\circ}\text{C}$.

..... $^{\circ}\text{C}$
(1)



Temperature (°F)

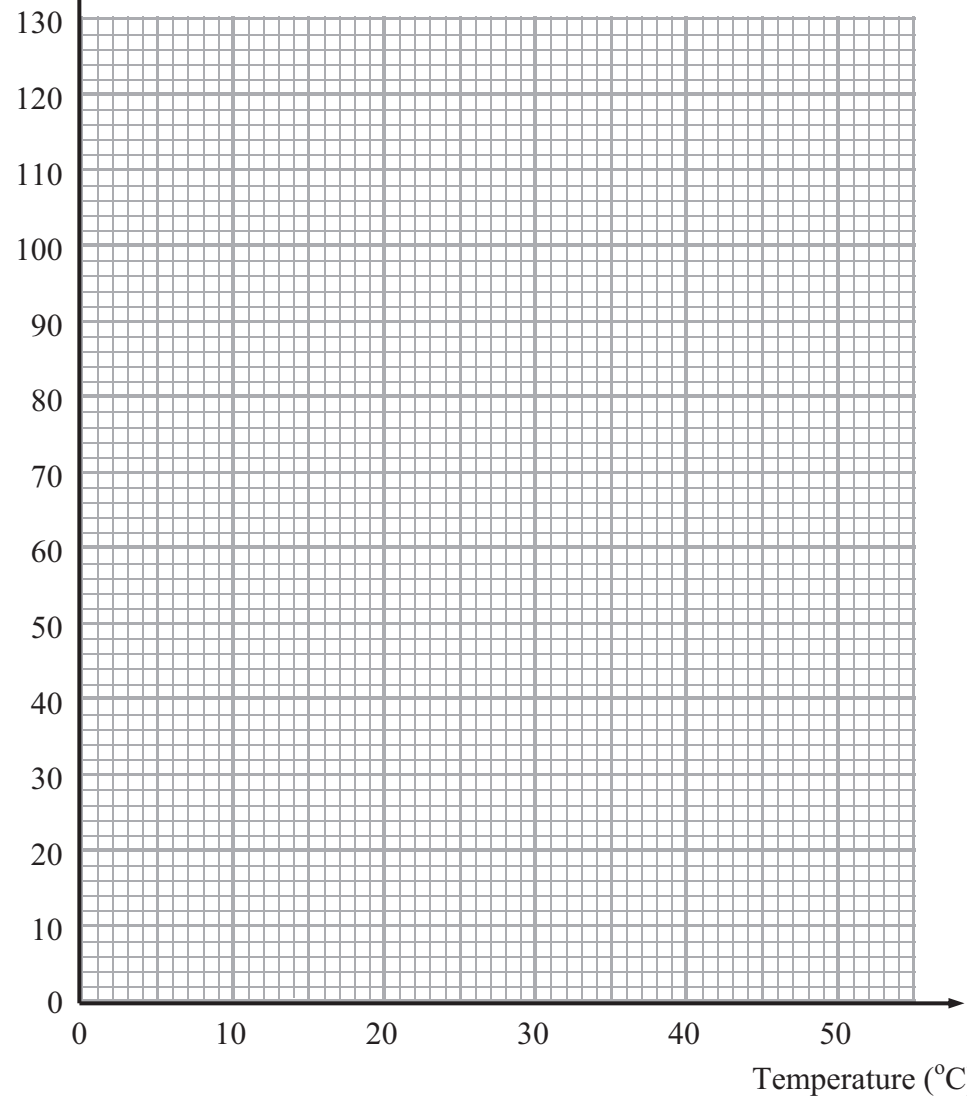

(Total for Question 7 is 6 marks)



- 8 Mrs Kunal's garden is in the shape of a rectangle.
Part of the garden is a patio in the shape of a triangle.
The rest of the garden is grass.

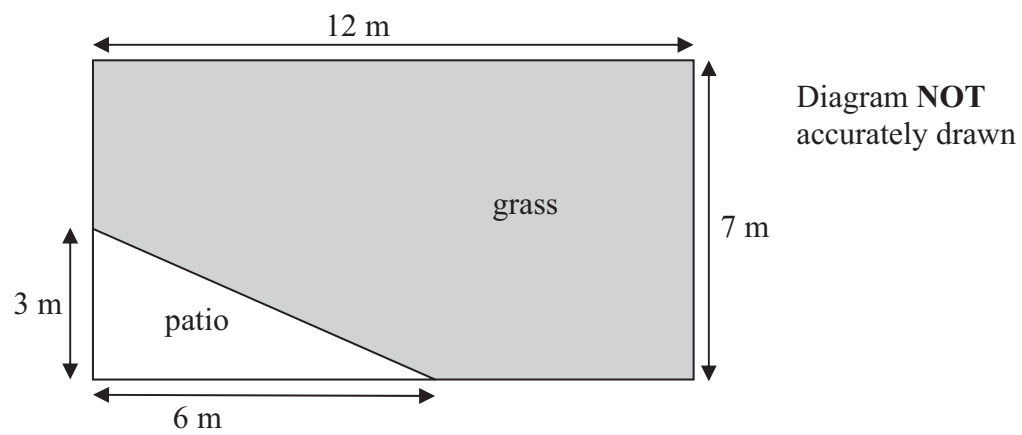

Mrs Kunal wants to spread fertiliser over all her grass.

One box of fertiliser is enough for 32 m^2 of grass.

How many boxes of fertiliser will she need?

You must show your working.

(Total for Question 8 is 4 marks)



9 Last year, Jora spent

30% of his salary on rent

$\frac{2}{5}$ of his salary on entertainment

$\frac{1}{4}$ of his salary on living expenses.

He saved the rest of his salary.

Jora spent £3600 on living expenses.

Work out how much money he saved.

£

(Total for Question 9 is 5 marks)



10 (a) Factorise fully $20w^2y + 24wy^3$

.....
(2)

(b) Factorise $m^2 + 3m - 40$

.....
(2)

(Total for Question 10 is 4 marks)



11 A water trough is in the shape of a prism.

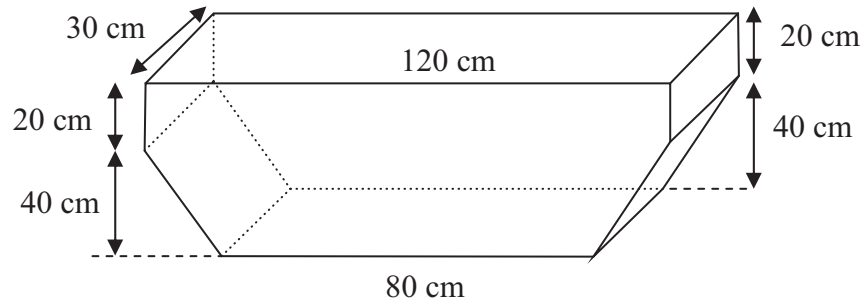

Diagram **NOT** accurately drawn

Hamish fills the trough completely.

Water leaks from the bottom of the trough at a constant rate.
2 hours later, the level of the water has fallen by 20 cm.

Water continues to leak from the trough at the same rate.

How many more minutes will it take for the trough to empty completely?

..... minutes

(Total for Question 11 is 6 marks)



12 (a) Simplify m^0

.....
(1)

(b) Simplify $(2x^6y^{-1})^3$

.....
(2)

.....
(Total for Question 12 is 3 marks)

13 Work out $(2.5 \times 10^9) \div (5 \times 10^3)$.
Give your answer in standard form.

.....
(Total for Question 13 is 2 marks)



*14 The diagram shows a pentagon.

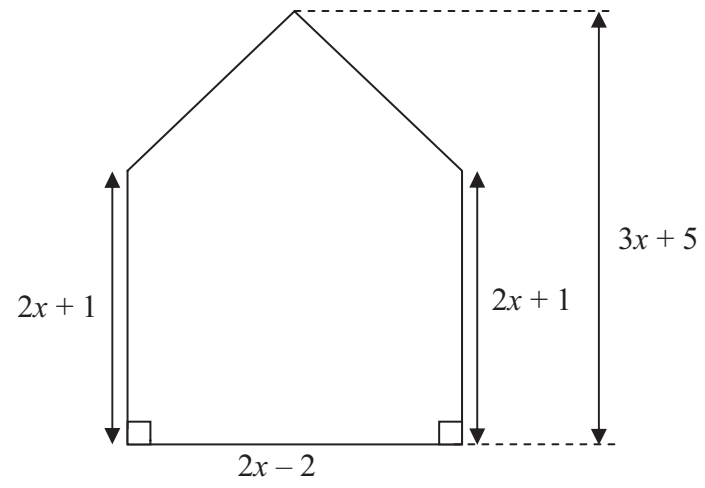

Diagram **NOT** accurately drawn

All measurements are in centimetres.

Show that the area of this pentagon can be written as $5x^2 + x - 6$

(Total for Question 14 is 4 marks)



15 Write as a single fraction in its simplest form

$$\frac{2x}{x-1} - \frac{7x-3}{x^2-1}$$

.....
(Total for Question 15 is 4 marks)



*16

Diagram NOT
accurately drawn

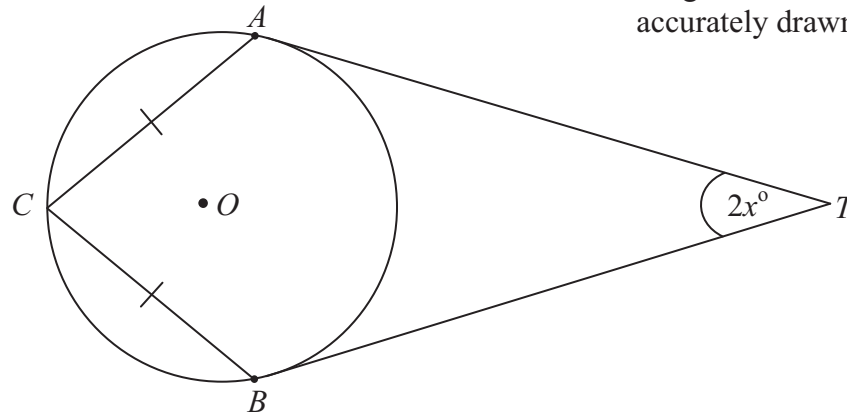

A , B and C are points on the circumference of the circle, centre O .
 TA and TB are tangents to the circle.
 $CA = CB$.
Angle $ATB = 2x^\circ$.
Prove that angle $ACB = (90 - x)^\circ$.

(Total for Question 16 is 5 marks)

TOTAL FOR PAPER IS 60 MARKS



N 3 8 3 9 6 A 0 1 5 1 6

BLANK PAGE

