



Oxford Cambridge and RSA

Friday 09 October 2020 – Morning

A Level Physics B (Advancing Physics)

H557/01 Fundamentals of Physics

Time allowed: 2 hours 15 minutes

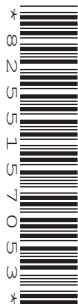

You must have:

- the Data, Formulae and Relationships Booklet

You can use:

- a scientific or graphical calculator
- a ruler (cm/mm)



Please write clearly in black ink. **Do not write in the barcodes.**

Centre number

--	--	--	--	--

Candidate number

--	--	--	--

First name(s)

Last name

INSTRUCTIONS

- Use black ink. You can use an HB pencil, but only for graphs and diagrams.
- Write your answer to each question in the space provided. If you need extra space use the lined pages at the end of this booklet. The question numbers must be clearly shown.
- Answer **all** the questions.
- Where appropriate, your answer should be supported with working. Marks might be given for using a correct method, even if your answer is wrong.

INFORMATION

- The total mark for this paper is **110**.
- The marks for each question are shown in brackets [].
- Quality of extended response will be assessed in questions marked with an asterisk (*).
- This document has **48** pages.

ADVICE

- Read each question carefully before you start your answer.

2
SECTION A

You should spend a maximum of 40 minutes on this section.

Write your answer for each question in the box provided.

Answer **all** the questions.

1 Which is the correct unit for electrical conductivity?

- A** AV^{-1}
- B** CV^{-1}
- C** Sm^{-1}
- D** Ωm

Your answer

[1]

2 A real image is formed by a lens of power 20 D.
Which statement is correct?

- A** All wavefronts passing through the lens have a final curvature of 20 D.
- B** The focal length of the lens is 0.5 m.
- C** The focal length of the lens is 5.0 m.
- D** The lens adds 20 D of curvature to all wavefronts passing through it.

Your answer

[1]

3

The following information is for use in questions 3 and 4.

The diagram shows how the digitisation of a sampled signal can lead to quantisation errors.

digital value

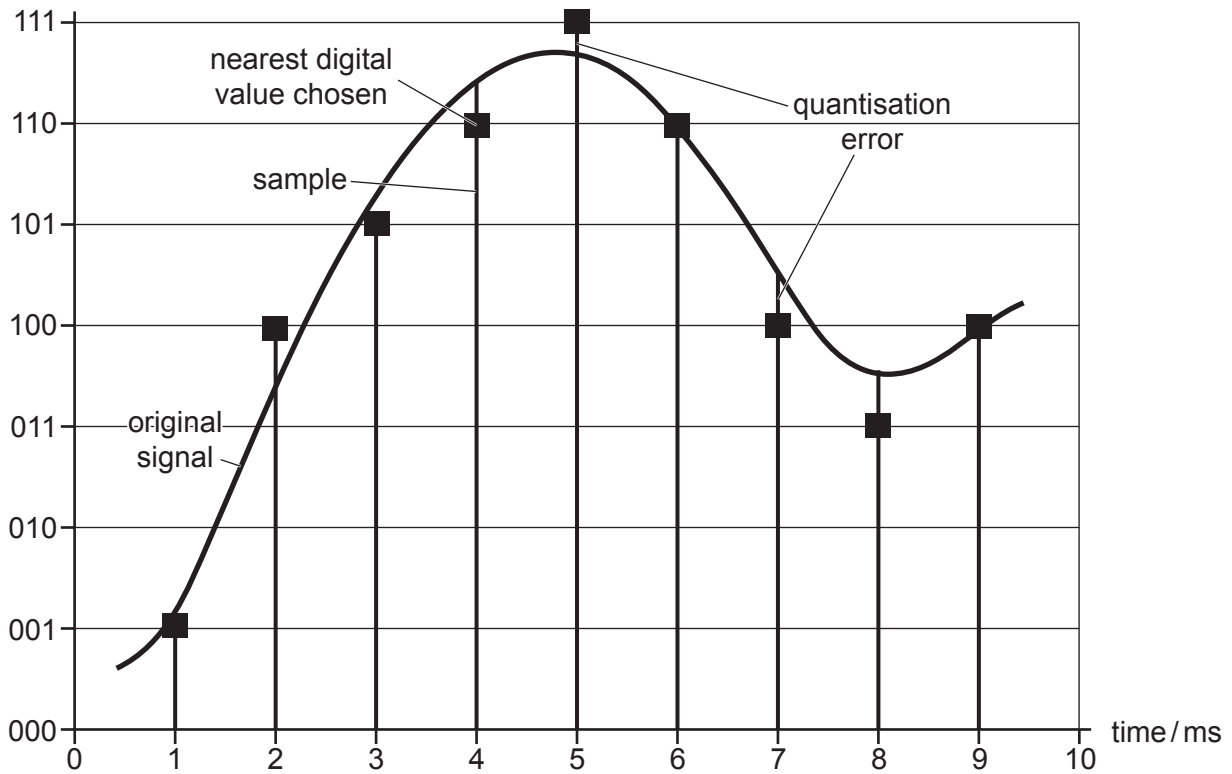

3 Quantisation errors can best be reduced by

- A decreasing the bits per sample.
- B decreasing the sampling frequency.
- C increasing the sampling frequency.
- D increasing the bits per sample.

Your answer

[1]

4 The bit rate (bits s^{-1}) of the digitised sample is:

- A 3
- B 30
- C 1110
- D 3000

Your answer

[1]

The following information is for use in questions 5 and 6.

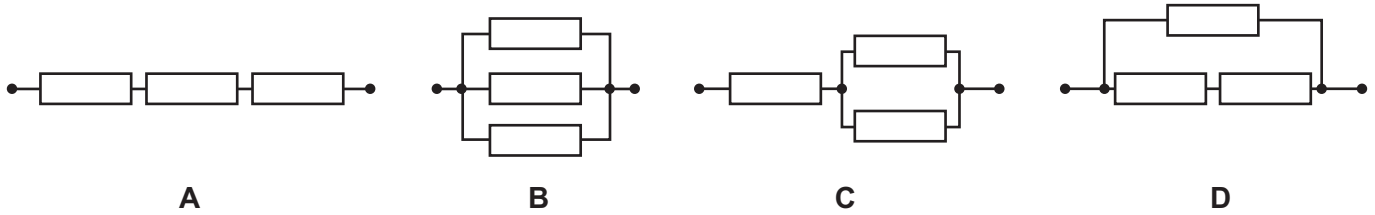

Three identical conductors of conductance 0.1 S are connected in arrangements **A**, **B**, **C** and **D**.

Which of the arrangements has:

5 the highest conductance?

Your answer

[1]

6 a conductance of 0.15 S ?

Your answer

[1]

The diagram is for use in questions 7 and 8.

The diagram shows a comet in elliptical orbit around a sun.

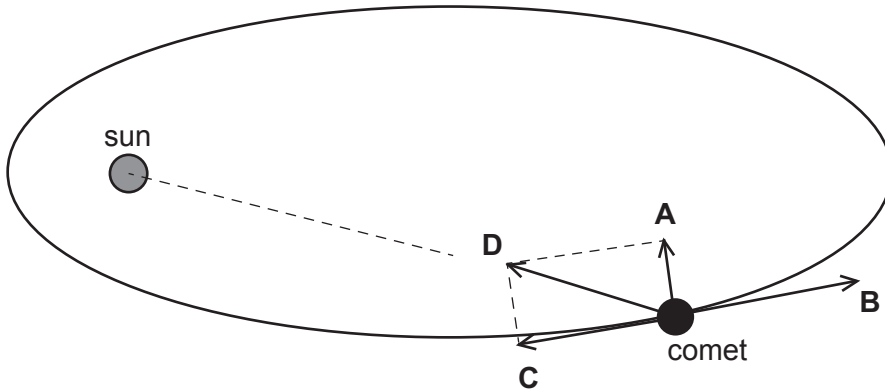

Four vectors **A**, **B**, **C** and **D** are also shown for one point in the orbit.

The vectors are:

- the instantaneous velocity of the comet
- the force of gravity
- the component of the force of gravity in line with the velocity
- the component of the force of gravity perpendicular to the velocity

7 Which vector alters only the magnitude of the velocity?

Your answer

[1]

8 Which vector alters only the direction of the velocity?

Your answer

[1]

- 9 The diagram shows a log dragged horizontally by a rope at 30° to the horizontal.

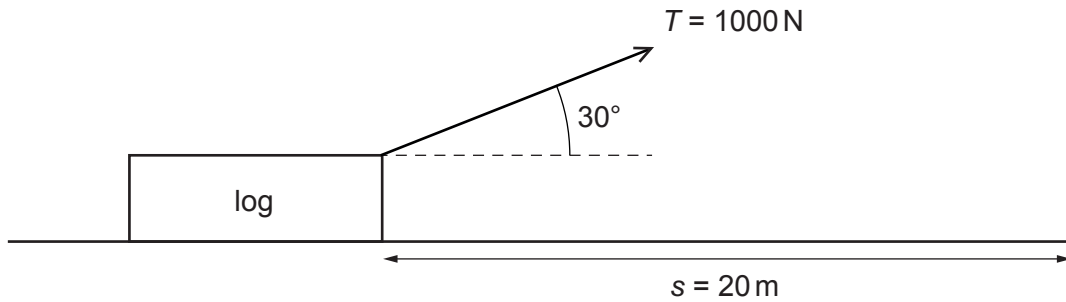

The tension T in the rope is 1000 N , and the log is dragged a horizontal distance s of 20 m .

How much work is done?

- A $1.0 \times 10^4 \text{ J}$
- B $1.7 \times 10^4 \text{ J}$
- C $2.0 \times 10^4 \text{ J}$
- D $1.7 \times 10^5 \text{ J}$

Your answer

[1]

- 10 Which statement about the relativistic factor $\gamma = \frac{1}{\sqrt{1 - \frac{v^2}{c^2}}}$ is correct?

- A as v tends to c , γ tends to 0
- B as v tends to 0 , γ tends to ∞
- C γ can be used to predict the energy of gamma ray photons
- D when $v = \frac{1}{2}c$, $\gamma \approx 1.15$

Your answer

[1]

- 11 The diagram shows a trap-door method to measure the acceleration due to gravity g of a steel ball. It uses a millisecond timer to measure the time t of fall h .

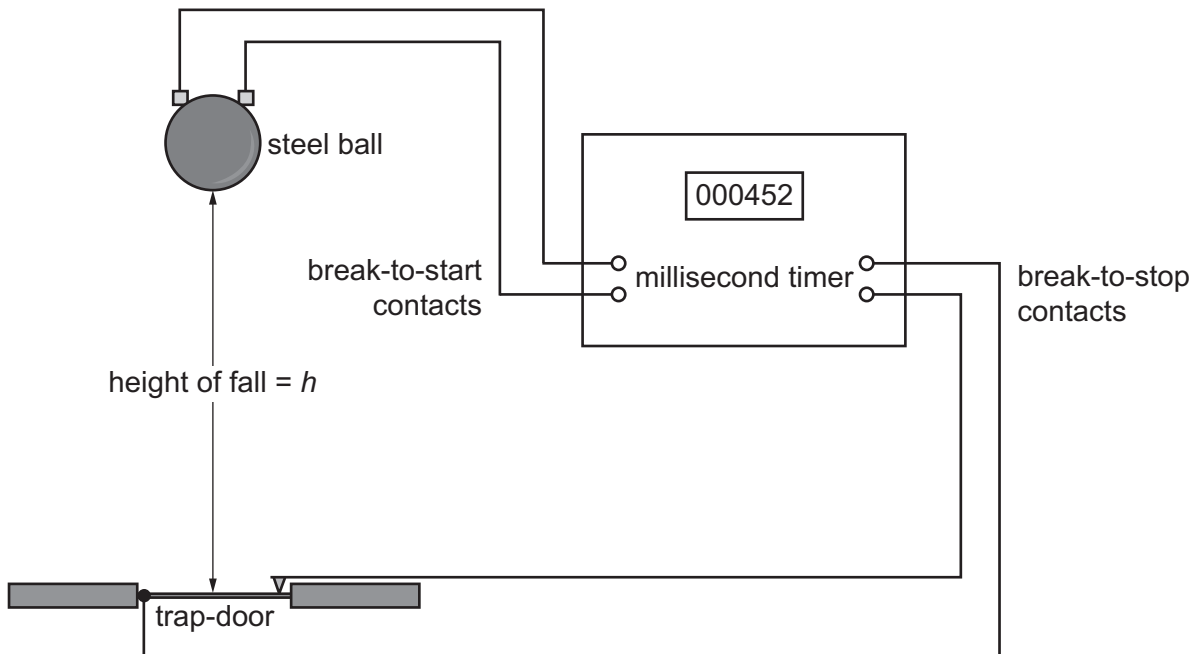

Which statement about this method is correct?

- A A graph of h plotted against t^2 has gradient g .
- B A graph of h plotted against t^2 has gradient $2g$.
- C A millisecond timer is very accurate and does not need calibration.
- D A millisecond timer is very precise but may need calibration.

Your answer

[1]

The diagram is for use in questions 12 and 13.

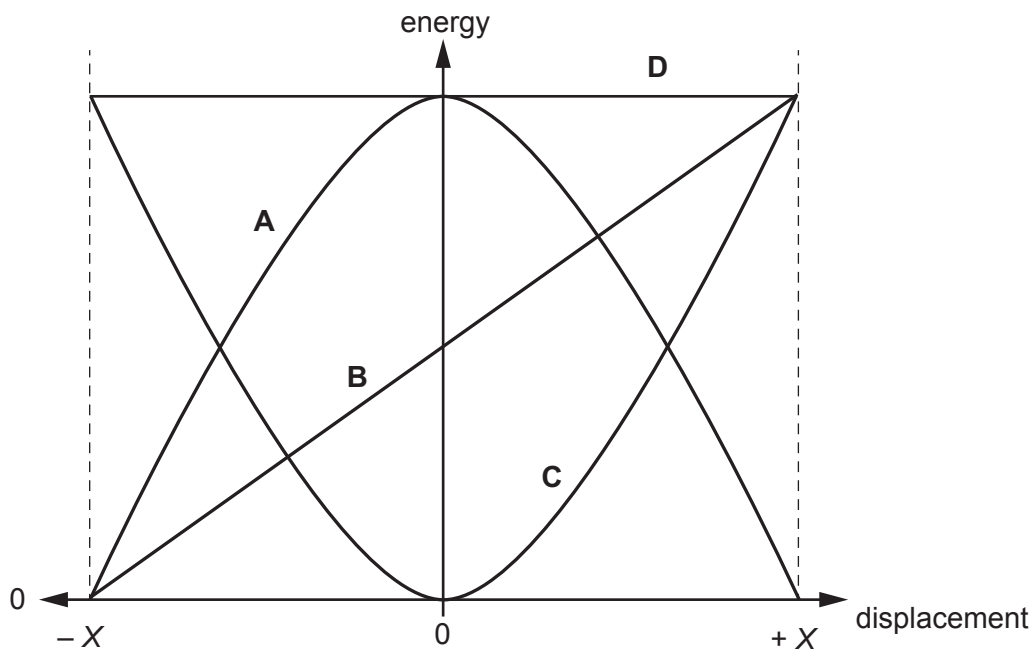

The diagram shows four possible graphs **A**, **B**, **C** and **D** of how energy changes with displacement X for a simple harmonic oscillator.

12 Which graph shows the variation of kinetic energy with displacement?

Your answer

[1]

13 Which graph shows the variation of total energy with displacement?

Your answer

[1]

14 Which statement about the kinetic theory of ideal gases is correct?

- A Particles have a significant volume compared to the gas volume.
- B Particles have average energy of exactly kT .
- C Particles have inelastic collisions with each other and the container.
- D Particles have negligible forces between them except during collision.

Your answer

[1]

15 An outdoor swimming pool contains 100m^3 of water and must be heated by 12°C .

specific heat capacity for water = $4200\text{J kg}^{-1}\text{K}^{-1}$

Which is the best estimate of the energy needed?

- A 10^5J
- B $5 \times 10^5\text{J}$
- C 10^8J
- D $5 \times 10^9\text{J}$

Your answer

[1]

The following information is for use in questions 16, 17 and 18.

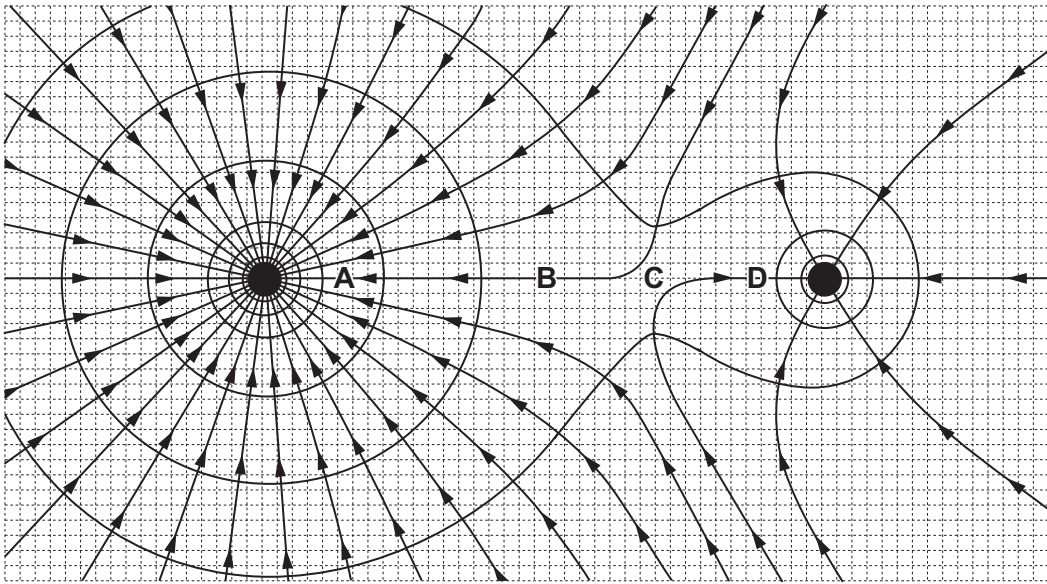

The diagram represents the gravitational field and potential for a planet – moon system. **A**, **B**, **C** and **D** are four points on the planet – moon line. The equipotentials are separated by equal potential differences.

16 At which point is the gravitational field strongest?

Your answer

[1]

17 Which point is the gravitational neutral point ($g_{\text{total}} = 0$)?

Your answer

[1]

18 From evidence on the diagram, which is the best estimate for $\frac{M_{\text{planet}}}{m_{\text{moon}}}$?

- A $\frac{1}{5}$
- B $\frac{1}{2}$
- C 1
- D 5

Your answer

[1]

19 There are similarities and differences between electric charges, fields and potentials and gravitational masses, fields and potentials.

Which **one** of the following statements is correct?

- A Both electrical and gravitational fields show attraction and repulsion.
- B Charges make potential energy hills for like charges, but potential energy wells for opposite charges, whereas only potential energy wells occur in gravity.
- C Electric field lines start and finish on charges, gravitational field lines start and finish on masses.
- D Neutral points of zero resultant field occur in gravitational fields but not electric fields.

Your answer

[1]

The following information is for use in questions 20 and 21.

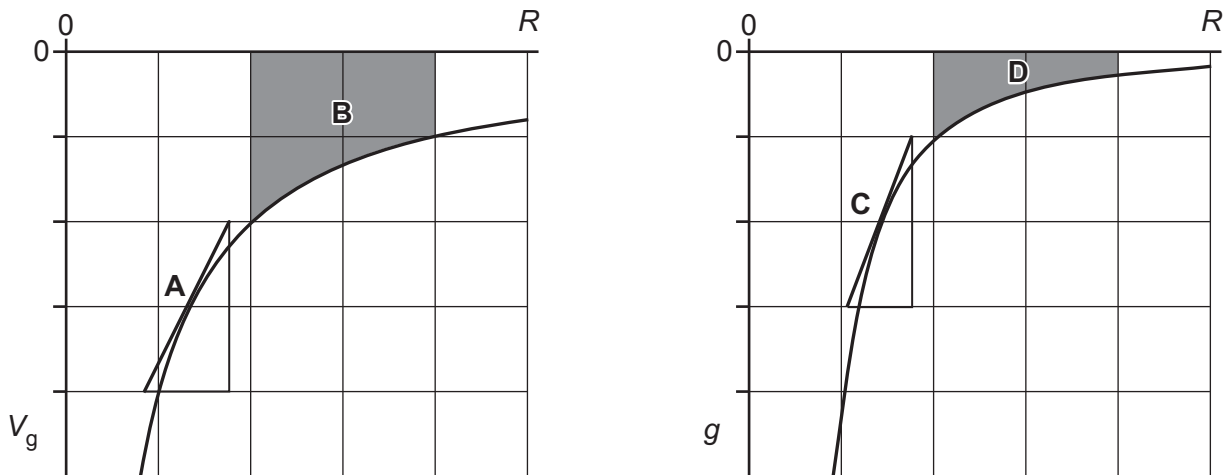

Two graphs are shown, the gravitational potential $V_g(R)$ and the gravitational field $g(R)$ for a spherical planet at the origin.

Four features are highlighted on the graphs, **gradient A**, **area B**, **gradient C**, and **area D**.

20 Which feature represents a change of gravitational potential ΔV_g between two points?

Your answer

[1]

21 Which feature represents the magnitude of the gravitational field g at a point?

Your answer

[1]

- 22 The speed of an alpha particle is 8 times the speed of a beta particle. They both travel through a 0.3T uniform magnetic field perpendicular to their path.

What is the magnitude of the ratio $\frac{\text{force on the alpha particle}}{\text{force on the beta particle}}$?

- A 2
- B 4
- C 6
- D 16

Your answer

[1]

The following information is for use in questions 23 and 24.

The diagram shows a potential divider containing three resistors, two fixed and one variable.

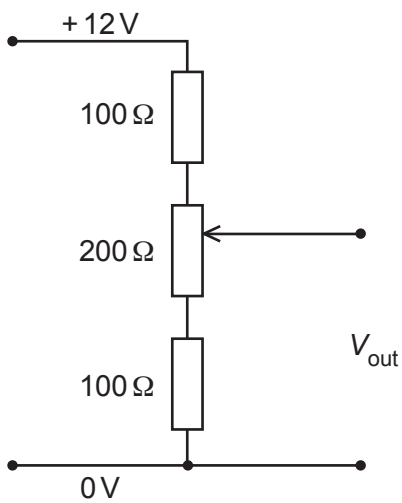

23 Which answer gives the correct output voltage range?

	Voltage range V_{out}/V
A	0 → 12
B	2 → 10
C	3 → 9
D	4 → 8

Your answer

[1]

24 The potential divider is set to its mid-point with $V_{\text{out}} = 6.0\text{V}$.

A 200Ω resistance is connected across the output.
Which statement about V_{out} is correct?

- A** It falls to 4.0V .
- B** It remains at 6.0V .
- C** It rises to 8.0V .
- D** It rises to 10.0V .

Your answer

[1]

25 The input current I to a simple transformer varies with time t as shown in the graph.

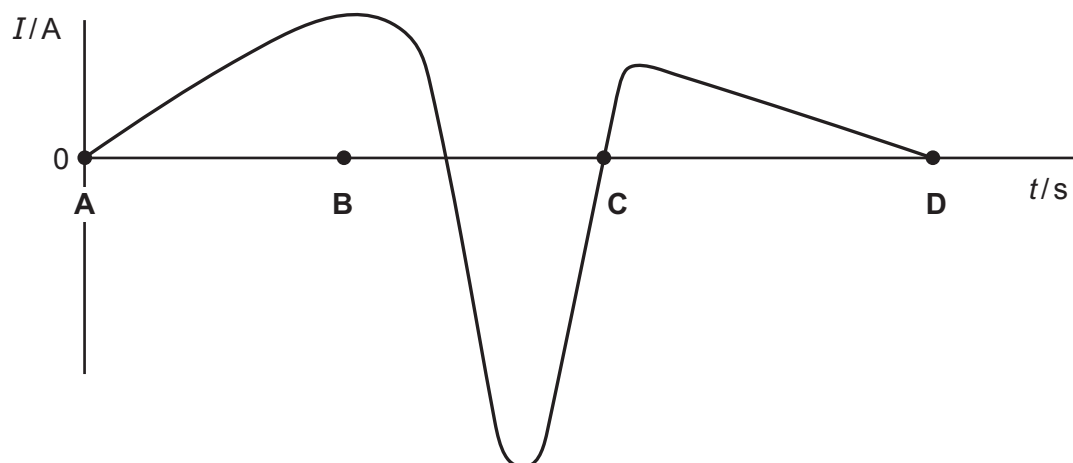

At which point in time **A**, **B**, **C** or **D** shown on the graph will the magnitude of the output voltage in the secondary coil be greatest?

Your answer

[1]

26 A light ray is incident on a water-glass boundary at angle $i = 60^\circ$.

What is the angle of refraction r within the glass?

	Refractive index
water	1.33
glass	1.50

A 50°

B 54°

C 63°

D 88°

Your answer

[1]

The following information is for use in questions 27 and 28.

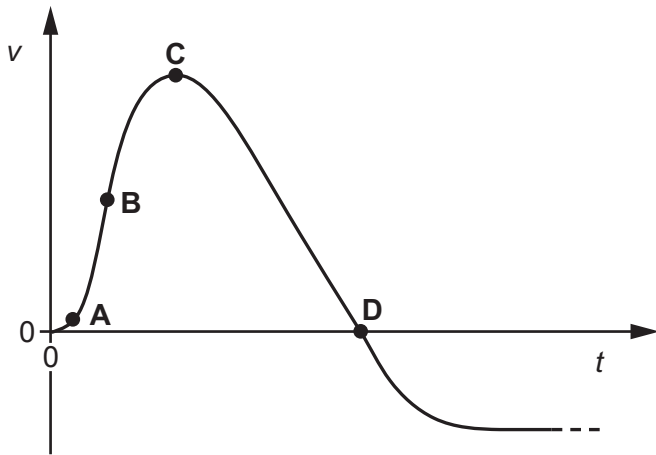

The graph shows how the vertical velocity v of a firework rocket changes with time t .

27 At which point **A**, **B**, **C** or **D** does the rocket run out of fuel?

Your answer

[1]

28 At which point **A**, **B**, **C** or **D** does the rocket experience the greatest force of air resistance?

Your answer

[1]

The following information is for use in questions 29 and 30.

An aircraft with a wingspan of 60 m flies horizontally at a velocity of 200 m s^{-1} .

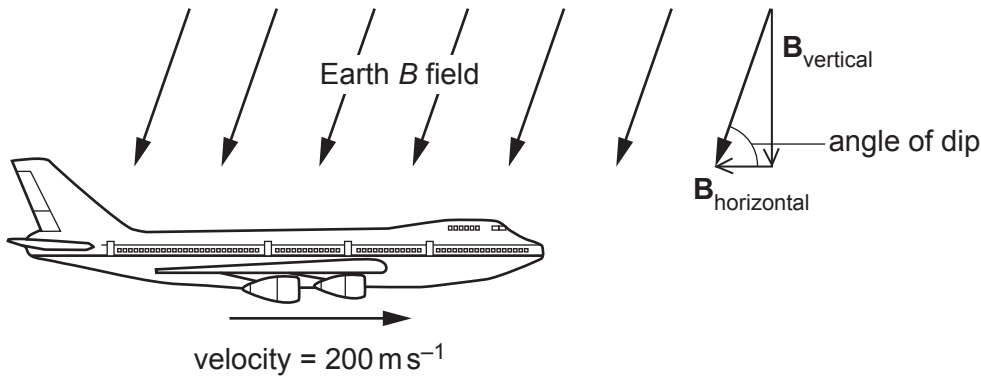

The Earth's magnetic flux density is $58 \mu\text{T}$ and the angle of dip is 70° .

The magnetic flux density can be considered as two perpendicular components B_{vertical} and $B_{\text{horizontal}}$ as shown.

29 Which is the best estimate of the e.m.f. induced across the plane's wingtips?

- A 240 mV
- B 650 mV
- C 740 mV
- D 2030 mV

Your answer

[1]

30 For **horizontal** flight at the position shown, in which direction should the plane fly to experience maximum induced e.m.f. from the Earth's magnetic field?

- A All directions give same induced e.m.f.
- B Plane should fly from East to West.
- C Plane should fly from North to South.
- D Plane should fly from South to North.

Your answer

[1]

SECTION B

Answer **all** the questions.

- 31 A ${}_{94}^{239}\text{Pu}$ nucleus absorbs a neutron and undergoes fission as shown in the equation below:



- (a) Complete the equation.

[1]

- (b) The masses of the nuclides (in atomic mass units) are:

Nuclide	Mass/u
${}_{94}^{239}\text{Pu}$	239.00055
${}_{54}^{134}\text{Xe}$	133.87575
${}_{40}^{103}\text{Zr}$	102.90345
${}_{0}^{1}\text{n}$	1.00867

Calculate the binding energy (in MeV) released during this fission.

$$1 \text{ u} = 931 \text{ MeV}$$

energy = MeV [3]

- 32 Each tyre of this truck has a volume of 4.0 m^3 .

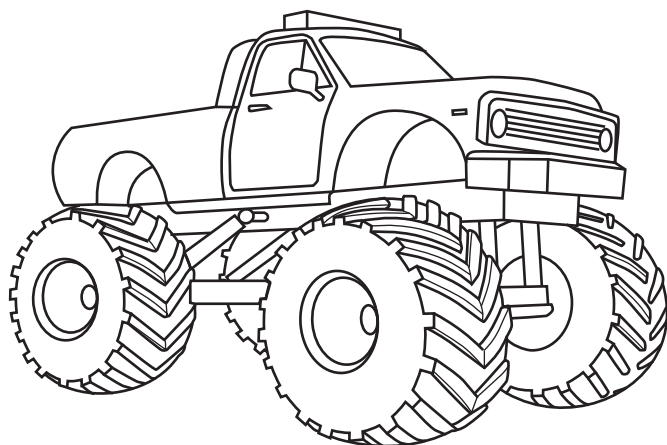

The air pressure in the tyres is 450 kPa when inflated at 15°C .

- (a) Calculate the number of moles of air in **one** tyre.

number of moles = [2]

- (b) During driving, the tyres warm to 47°C and the volume remains constant.

Using ideas from kinetic theory, explain what happens to the air pressure in the tyres.

.....

 [3]

- 33 The figure shows two possible paths of alpha particles of the same initial kinetic energy near a massive atomic nucleus.

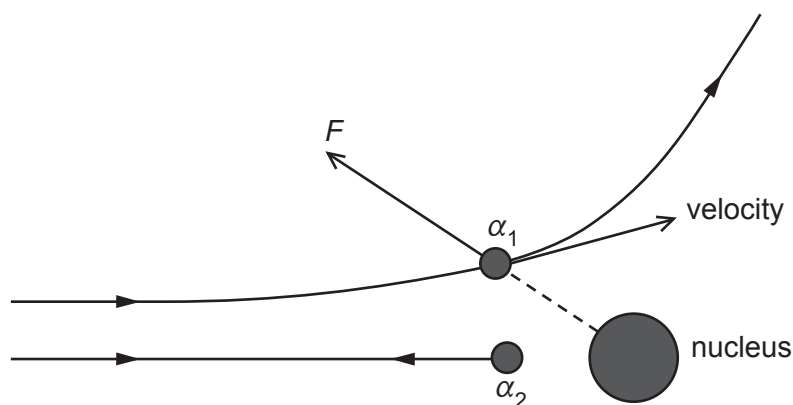

- (a) State one effect of the repulsive force F on the motion of the alpha particle at position α_1 .

.....
 [1]

- (b) At the position α_2 the alpha particle is as close as it can get to the nucleus.

State what has happened to the original kinetic energy of the alpha particle.

.....
 [1]

- (c) (i) What combination of alpha particle kinetic energy and proton number Z of the target nucleus will result in the closest possible approach?

Place a tick in the correct box for closest possible approach.

	Low proton number Z of target nucleus	High proton number Z of target nucleus
Low alpha kinetic energy		
High alpha kinetic energy		

[1]

- (ii) A 7.7 MeV alpha particle makes a head-on collision with an aluminium nucleus ${}_{13}^{27}\text{Al}$.

Calculate the distance of closest approach between the centres of the alpha particle and the aluminium nucleus.

distance of closest approach = m [2]

34 The graph shows the stress against strain relationship for a spider silk up to breaking stress.

The line **AB** is an extension of the linear part of the spider silk curve.

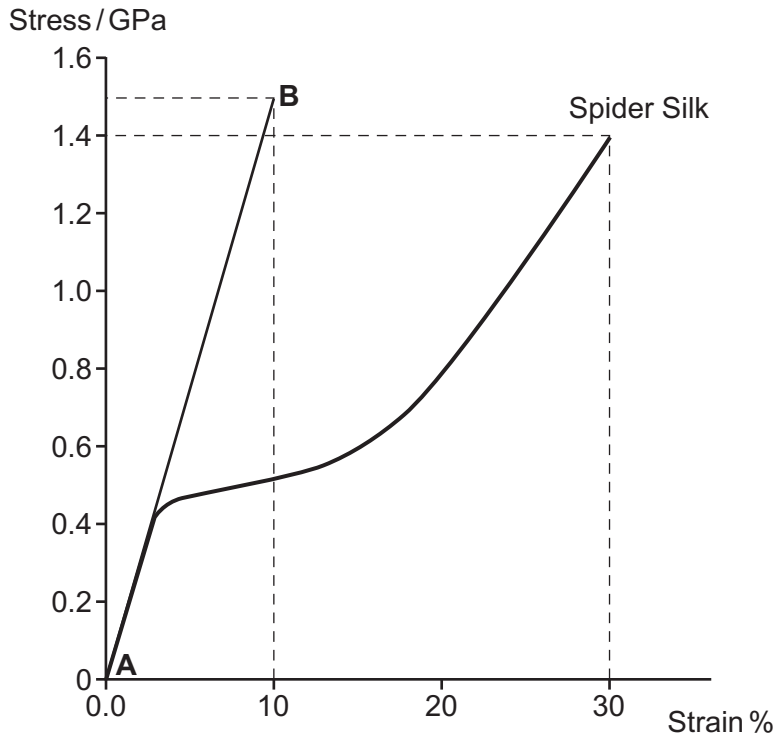

(a) Calculate the Young modulus for the elastic region of this spider silk.

Young modulus = Pa [2]

(b) This table compares some mechanical properties of spider silk and high tensile steel.

	Breaking stress σ_B / GPa	Density ρ / kg m ⁻³
Spider silk	1.4	1.2×10^3
High tensile steel	2.8	7.8×10^3

Steel is twice as strong as spider silk.

Show that for fibres of equal dimensions the spider silk has about three times the $\frac{\text{strength}}{\text{weight}}$ ratio of steel.

[2]

35 Fig. 35a shows an arrangement of microwave transmitter T, receiver R and a metal mirror M.

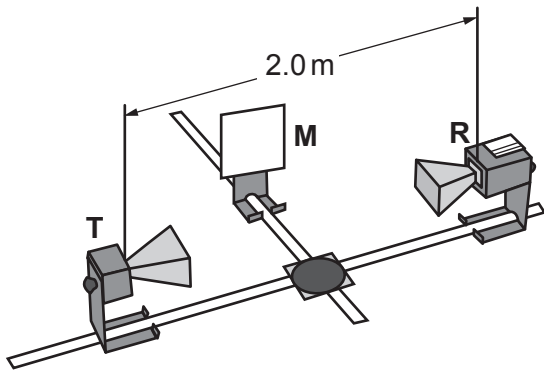

Fig. 35a

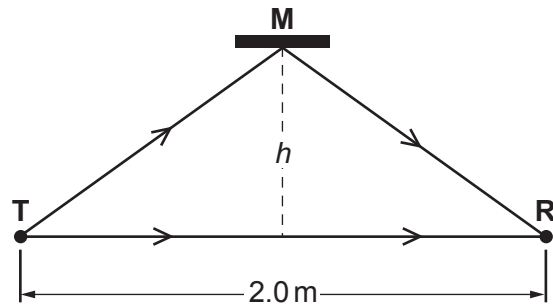

Fig. 35b

Fig. 35b shows the arrangement from above. The distance TR = 2.0 m is kept constant.

The intensity at the receiver rises and falls as the distance h is increased.

(a) Explain why the intensity varies as it does.

.....

.....

.....

..... [2]

(b) The first two maxima in signal occur at $h = 0.123$ m and 0.213 m.

Use the data to calculate the wavelength λ of the microwaves.

wavelength $\lambda =$ m [3]

SECTION C

Answer **all** the questions.

36 This question considers two methods for digitising sound signals: CD sampling and internet music streaming.

(a) For CD quality, sound is sampled at 44 kHz using 16 bit samples for each of the stereo channels.

(i) Show that the information rate needed for this digitisation during playback is greater than 1 Mbit s^{-1} .

[1]

(ii) A CD typically stores 840 MBytes.

Show that the total playback time is about 80 minutes for such a CD.

time = minutes [2]

(b) **Fig. 36.1** shows 10 ms of electrical output from a microphone. This waveform is to be digitised for internet streaming.

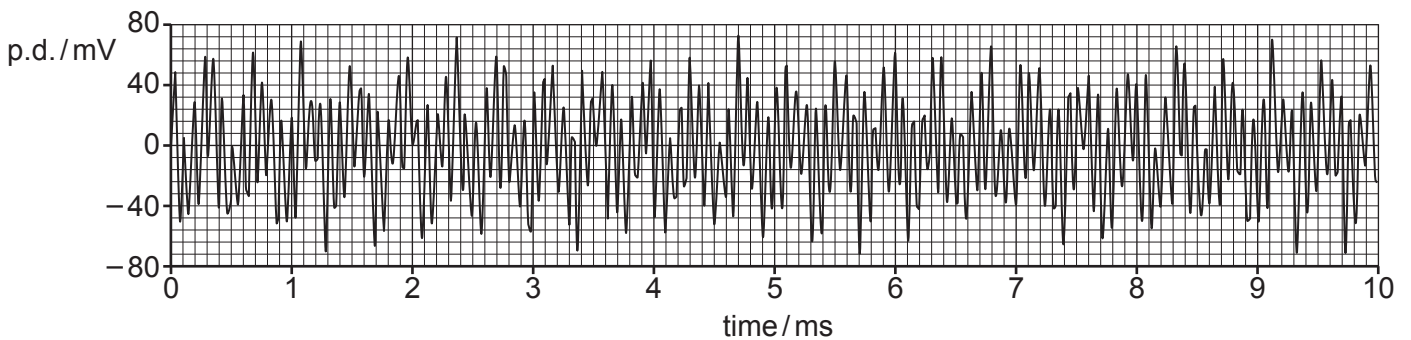

Fig. 36.1

(i) State the evidence from **Fig. 36.1** that there is more than one frequency present in the waveform.

.....
..... [1]

A sound spectrum displays the different frequencies present in a short sample of a sound. It can be shown as a graph of signal amplitude as a function of frequency.

Fig. 36.2 shows the sound spectrum of the 10 ms sample of the waveform in **Fig. 36.1**.

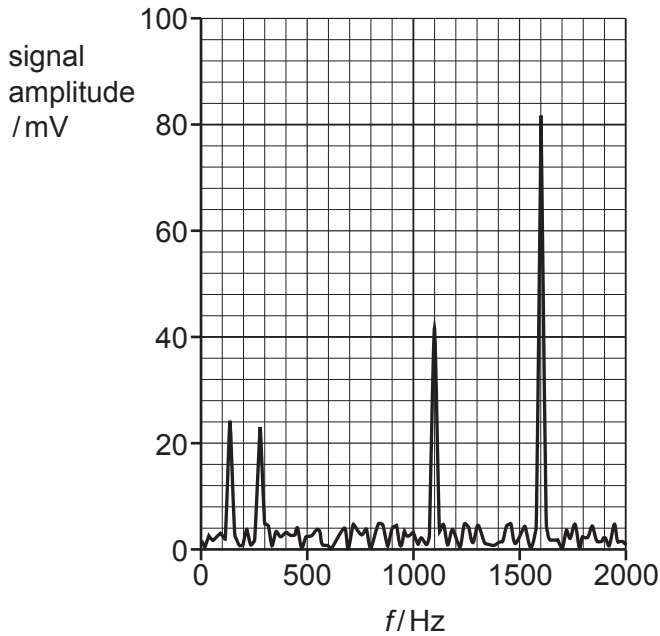

Fig. 36.2

(ii) Suggest why it is possible to ignore signals of under about 5 mV.

.....
 [1]

(iii) Some humans have perfect pitch judgement for sound, accurate to ± 1 Hz.

Calculate the minimum number of bits needed to code for this precision for the frequency of the 1600 Hz peak in **Fig. 36.2**.

minimum number of bits = [1]

- (iv) To digitise this 10 ms sample of the sound wave **each** of the four peaks in the sound spectrum of **Fig. 36.2** can be coded by 24 bits.

Show that the minimum rate of data transfer that the music streaming site must use to transmit this information is about $1/100$ that of CD information rate in **(a)(i)**.

[2]

- 37 Fig. 37.1 shows how an approximation to a parabolic trajectory ($x - y$ graph) can be built in steps for a projectile launched at 45° , undergoing constant downward acceleration at $g = 10 \text{ m s}^{-2}$. The trajectory is built by drawing scaled velocity vector triangles on the trajectory every 2 seconds to represent the displacement during that interval.

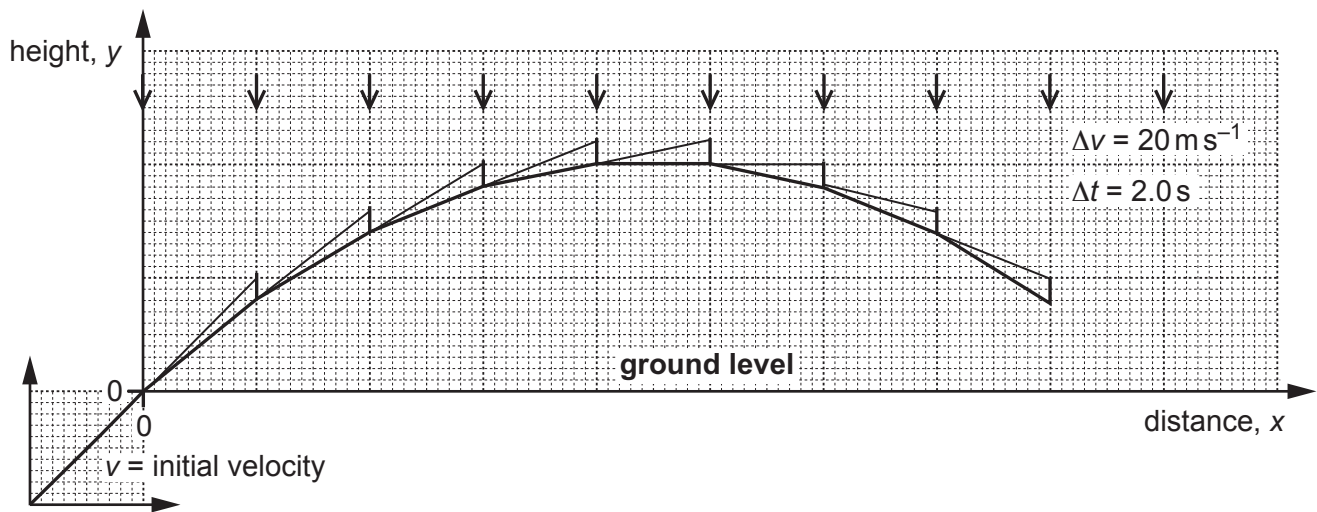

Fig. 37.1

- (a) (i) Complete Fig. 37.1 to show the complete trajectory back to ground level. [1]
- (ii) The initial horizontal and vertical components of the velocity are both 100 m s^{-1} . Show that the size of the initial projection velocity v is about 140 m s^{-1} .

[1]

- (iii) The time intervals of the steps in the approximation are $\Delta t = 2.0$ s.
The change in vertical velocity over each time interval of 2.0 s is 20 m s^{-1} downwards.

- 1 Calculate the horizontal distance travelled by the projectile during a 2.0 s time interval.

horizontal distance during 2.0 s = m [1]

- 2 Calculate the horizontal range R of the projectile in this model.

range $R =$ m [1]

- (iv) The horizontal range R of a projectile launched at initial velocity v at angle θ to the horizontal is given by

$$R = \frac{v^2 \sin 2\theta}{g}.$$

Use the equation to calculate the range R of the projectile motion modelled in **Fig. 37.1**.

range $R =$ m [1]

30
BLANK PAGE

PLEASE DO NOT WRITE ON THIS PAGE

Question 37 continues on page 31

(b) In a demonstration, a projectile is fired from a gun as shown in Fig. 37.2.

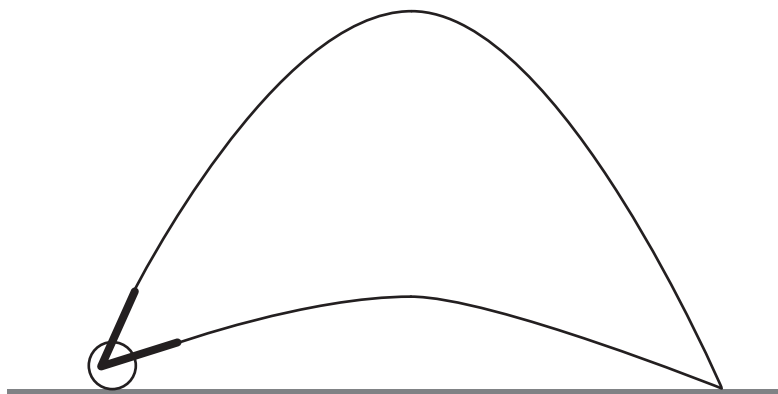

Fig. 37.2 (not to scale)

The projectile leaves the gun at a velocity of 140 m s^{-1} at an angle to the horizontal of 75° . A second projectile is fired from a gun at the same position and speed but at an angle of 15° to the horizontal.

Calculate how much later in time the second gun should be fired for both projectiles to land at the same point on the ground at the same time. Ignore the effects of air resistance.

time delay = s [3]

(c)* **Fig. 37.3** shows the effect of air resistance on the horizontal and vertical components of velocity for the projectile launched at 75° in (b). Air resistance will affect the path of the projectile through the air.

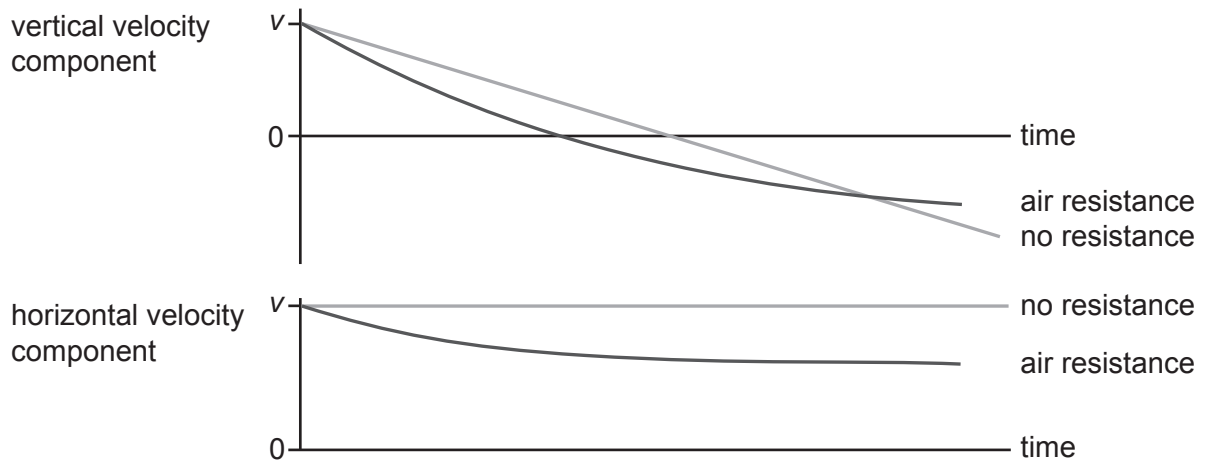

Fig. 37.3

Describe and explain the effect of air resistance on the motion of the projectile.

Describe how air resistance affects the shape of the trajectory, the maximum height and range.

Explain how air resistance occurs and why the size of the effect on the vertical component and the horizontal component of the motion is different.

You may find it useful to include labelled diagrams in your answer.

[6]

38 The diagram shows hydrogen spectrum lines in the lab and from a supernova in a distant galaxy that is receding (moving away) from Earth.

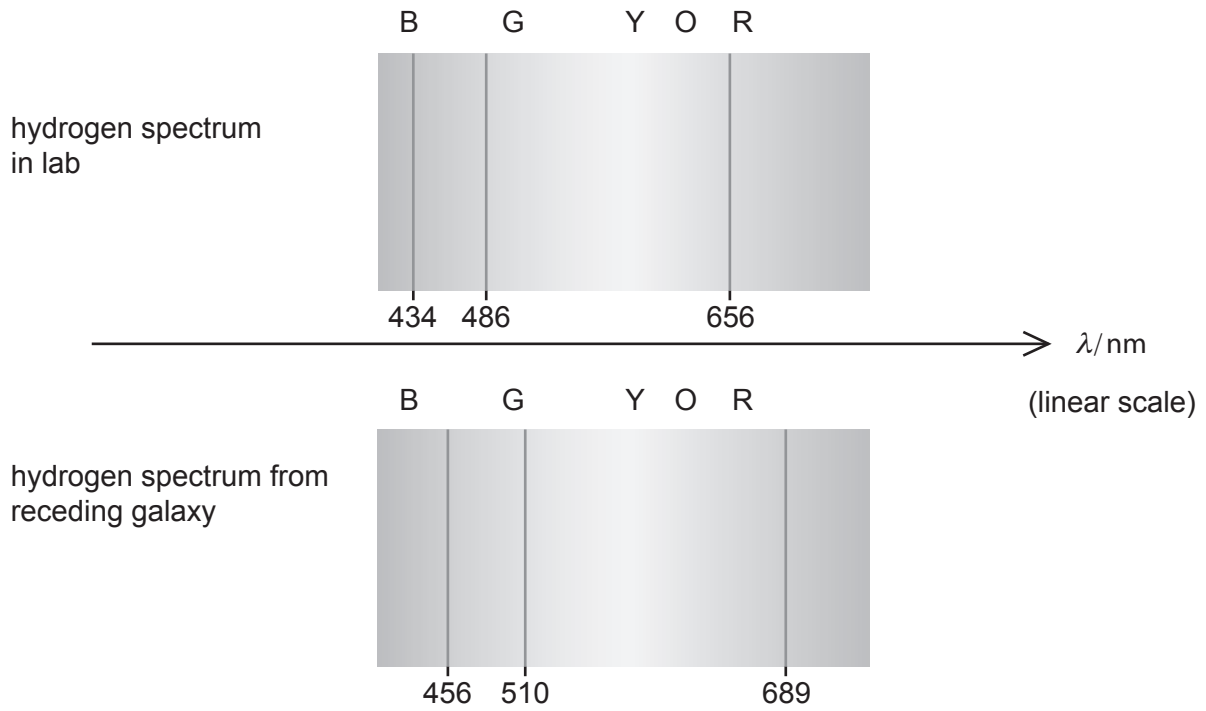

(a) Explain why the spectrum from the receding galaxy is described as red-shifted.

.....
 [1]

(b) Choose any **two** lines in the spectrum to show that the shift in wavelength $\Delta\lambda$ is proportional to the wavelength in the lab λ .

[2]

(c) For non-relativistic recession velocities v , the red-shift is given by the equation:

$$\frac{\Delta\lambda}{\lambda} = \frac{v}{c}$$

Use this formula to show that the recession velocity of the galaxy is greater than 10^7 m s^{-1} .

[1]

- 39* The age of atoms in terrestrial rocks can be estimated by considering the ratio of numbers of atoms of radioactive isotopes.

Today the number ratio for the isotopes $^{235}\text{U}/^{238}\text{U} = 0.00725$ in terrestrial rocks. This table shows the half-lives of the two isotopes.

Isotope	Half-life/ 10^9 years
^{235}U	0.71
^{238}U	4.50

Assume that when the Uranium atoms were produced they were in equal abundance, i.e. $^{235}\text{U}/^{238}\text{U} = 1$.

Estimate the age of these atoms in terrestrial rocks.

Explain why the isotope ratio changes with time. Justify the assumption above and state any other assumptions that you make to calculate your estimate. **[6]**

.....

.....

.....

.....

.....

.....

.....

.....

.....

.....

.....

.....

.....

.....

.....

Additional answer space if required

.....

.....

.....

.....

.....

.....

- 40** This question is about the Boltzmann factor and cooking crème brûlée (egg custard topped with lightly burnt sugar).

At room temperature weak hydrogen bonds keep the shape of protein molecules in egg yolks. A typical hydrogen bond energy for proteins is 40 kJ mol^{-1} .

- (a) (i)** Show that the energy per hydrogen bond is about $7 \times 10^{-20} \text{ J}$.

[2]

To set the custard, the hydrogen bonds have to be broken by baking it in an oven at 70°C .

- (ii)** Calculate the typical thermal energy of molecules at 70°C (343 K).

thermal energy = J **[1]**

- (iii)** Breaking hydrogen bonds alters the protein molecules and thickens the custard.

Calculate the fraction of water molecules at 70°C that have sufficient thermal energy to break the hydrogen bonds.

fraction of molecules = **[2]**

- (iv) Only a low fraction of molecules has enough energy to break hydrogen bonds. Explain how the cooking reaction can still proceed at a reasonable rate at 70°C.

.....

.....

.....

..... [2]

- (b) To lightly burn the sugar on top of the custard, much stronger covalent bonds must be broken.

The graph shows how the Boltzmann factor changes with temperature for the weak hydrogen bonds in egg protein and for the stronger covalent bonds in sugar, (**both** scales are logarithmic).

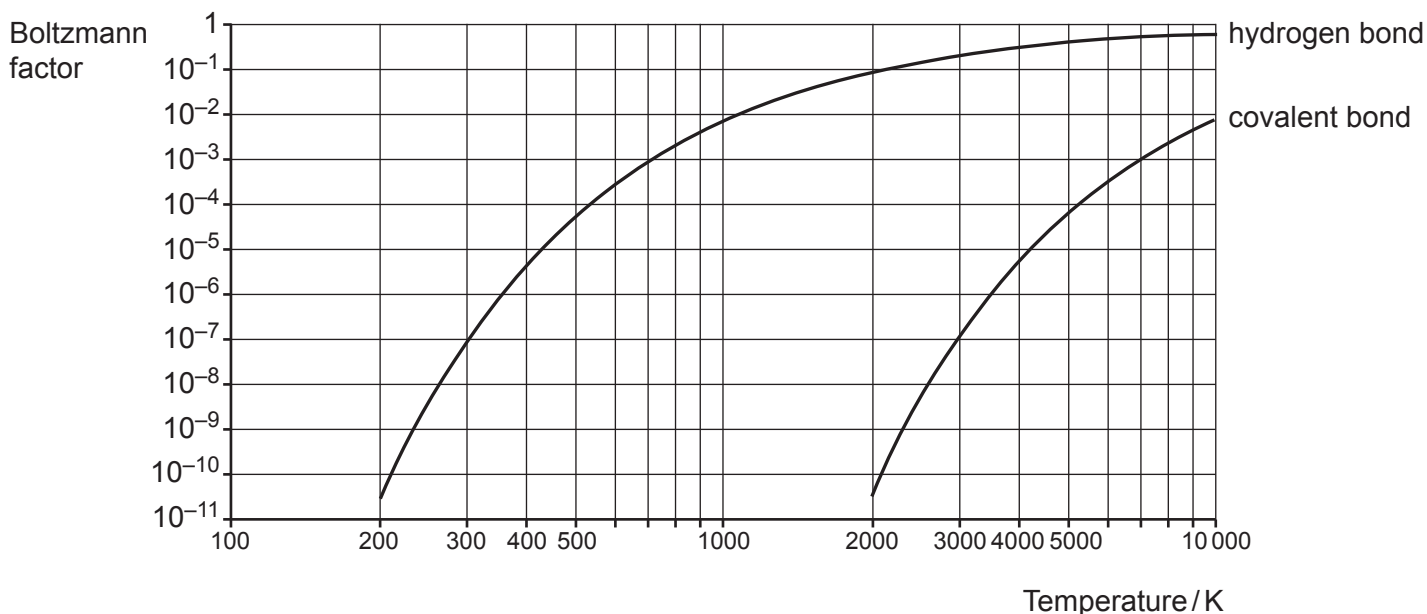

Use the data in the graphs to estimate the energy required to break the covalent bonds in sugar.

energy = J [1]

41 This question is about the irradiation of food with γ -rays to reduce the risk of bacterial infection. The food is stacked on a conveyor system and moves slowly past the source.

The food is irradiated with a dose of 500 Gy from exposure to a cobalt-60 gamma ray source.

(a) (i) Suggest why a γ -ray source is chosen for this purpose rather than α or β .

.....
.....
.....
.....
.....
..... [2]

(ii) The food is irradiated for 5 minutes to give a dose of 500 Gy. Calculate the dose in Gy that would be received by a worker exposed to the gamma source for one second.

dose received = Gy [2]

42
BLANK PAGE

PLEASE DO NOT WRITE ON THIS PAGE

Question 42 starts on page 43

42 Fig. 42.1 shows the uniform field between parallel plates (ignore end effects).

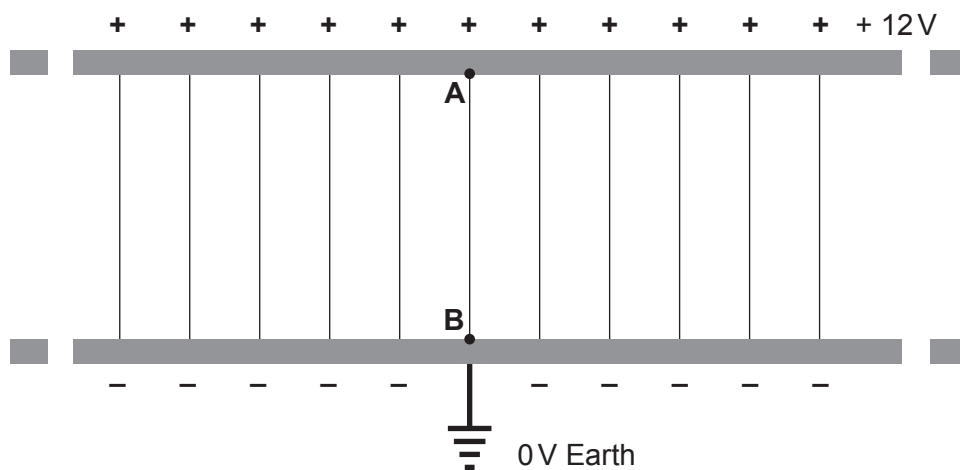

Fig. 42.1

(a) (i) Draw on Fig. 42.1 above the equipotential line at + 8.0V.

[1]

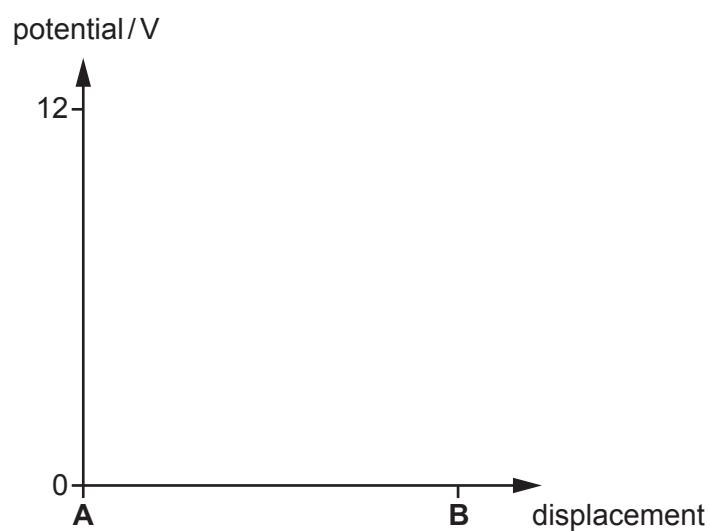

Fig. 42.2

(ii) Draw on Fig. 42.2 a line which shows how the potential varies along the field line **AB**.

[1]

(iii) The distance **AB** is 5.0 mm.

Calculate the electric field between the plates.

electric field = Vm^{-1} [1]

- (b) **Fig. 42.3** shows the circuit for an experiment that gives evidence that mercury atoms have a discrete energy level. Electrons are emitted from the heated filament and accelerate towards the anode grid through low pressure mercury gas.

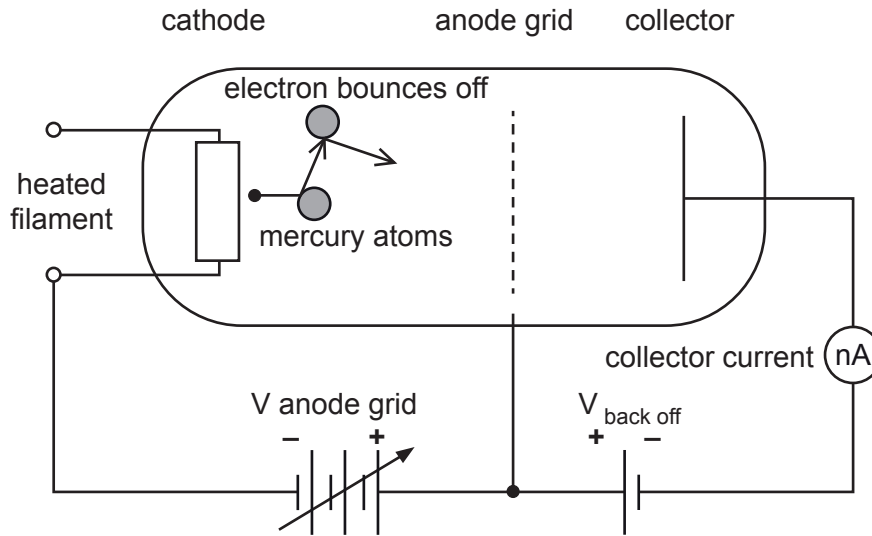

Fig. 42.3

The electrons collide many times with mercury atoms on their way. They pass through the open anode grid and, if they have sufficient kinetic energy, can climb the small potential hill provided by $V_{\text{back off}}$ ($\approx 0.2\text{V}$) to reach the collector. This flow of electrons registers as the collector current.

Fig. 42.4 shows how the electron current arriving at the collector varies with the voltage of the anode grid.

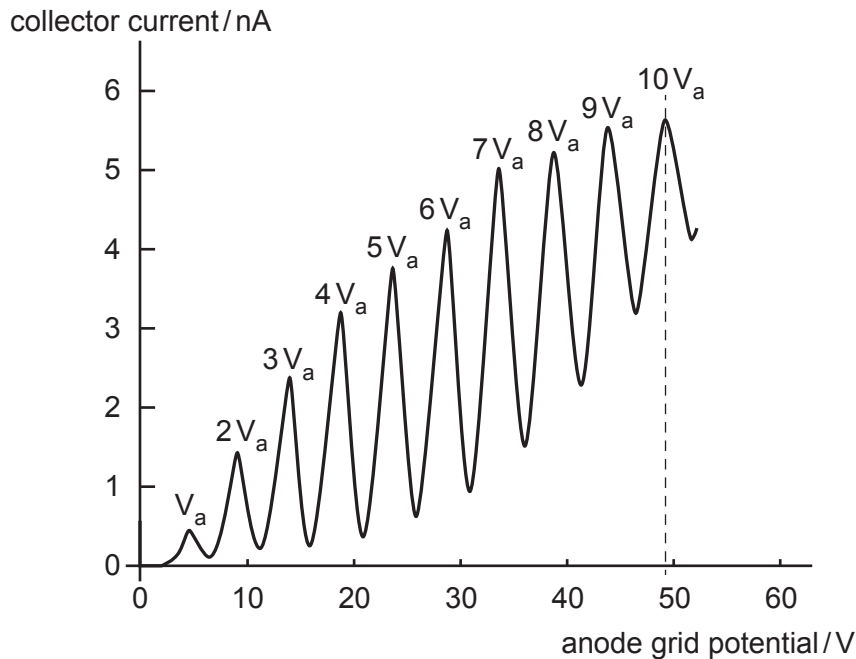

Fig. 42.4

The graph has a series of **equally** spaced peaks in current at anode voltages: V_a , $2V_a$, $3V_a$ etc.

- (i) Use data from **Fig. 42.4** to show that the value of the velocity of the electron when accelerated through the potential difference V_a is greater than $1 \times 10^6 \text{ m s}^{-1}$.

[2]

- (ii) When an electron of mass m collides **elastically** with a mercury atom of much greater mass M , the fraction of kinetic energy it transfers is given by the equation:

$$\frac{\Delta E}{E} = \frac{4 M m}{(M + m)^2} \quad \text{where } M \approx 3.7 \times 10^5 m.$$

Show that in this case the fraction $\frac{\Delta E}{E} \approx 10^{-5}$.

[1]

- (iii) Even after hundreds of collisions the electron will have lost negligible energy by elastic collisions.

Explain how the dips in the graph **Fig. 42.4** suggest that the difference in energy between two energy levels in mercury is about 5 eV.

.....

.....

.....

.....

..... [2]

END OF QUESTION PAPER

ADDITIONAL ANSWER SPACE

If additional space is required, you should use the following lined page(s). The question number(s) must be clearly shown in the margin(s).

A large area of lined paper for writing. It features a vertical solid line on the left side, creating a margin. The rest of the page is filled with horizontal dotted lines, providing space for writing answers.

A large rectangular area with a solid vertical line on the left and horizontal dotted lines, intended for writing answers.



Copyright Information

OCR is committed to seeking permission to reproduce all third-party content that it uses in its assessment materials. OCR has attempted to identify and contact all copyright holders whose work is used in this paper. To avoid the issue of disclosure of answer-related information to candidates, all copyright acknowledgements are reproduced in the OCR Copyright Acknowledgements Booklet. This is produced for each series of examinations and is freely available to download from our public website (www.ocr.org.uk) after the live examination series. If OCR has unwittingly failed to correctly acknowledge or clear any third-party content in this assessment material, OCR will be happy to correct its mistake at the earliest possible opportunity.

For queries or further information please contact The OCR Copyright Team, The Triangle Building, Shaftesbury Road, Cambridge CB2 8EA.

OCR is part of the Cambridge Assessment Group; Cambridge Assessment is the brand name of University of Cambridge Local Examinations Syndicate (UCLES), which is itself a department of the University of Cambridge.