

**GCSE (9–1) Chemistry A (Gateway Science)**

**H**

**J248/04 Paper 4 (Higher Tier)**

Sample Question Paper

**Date – Morning/Afternoon**

Version 2.1

Time allowed: 1 hour 45 minutes

**You must have:**

- the Data Sheet

**You may use:**

- a scientific or graphical calculator
- a ruler



First name

Last name

Centre number

Candidate number

**INSTRUCTIONS**

- Use black ink. You may use an HB pencil for graphs and diagrams.
- Complete the boxes above with your name, centre number and candidate number.
- Answer **all** the questions.
- Write your answer to each question in the space provided.
- Additional paper may be used if required but you must clearly show your candidate number, centre number and question number(s).
- Do **not** write in the bar codes.

**INFORMATION**

- The total mark for this paper is **90**.
- The marks for each question are shown in brackets [ ].
- Quality of extended response will be assessed in questions marked with an asterisk (\*).
- This document consists of **28** pages. Any blank pages are indicated.

**SECTION A**

Answer **all** the questions.

You should spend a maximum of 30 minutes on this section.

**1** Which statement is correct for a Group 1 element?

- A** It dissolves in water to form a bleach.
- B** It is an inert gas.
- C** It is a non-metal.
- D** It reacts with water to form hydrogen.

Your answer

**[1]**

- 2 The bar chart shows the amount of some fractions made from 100 tonnes of crude oil by fractional distillation.

It also shows the amount of each fraction needed for everyday uses.

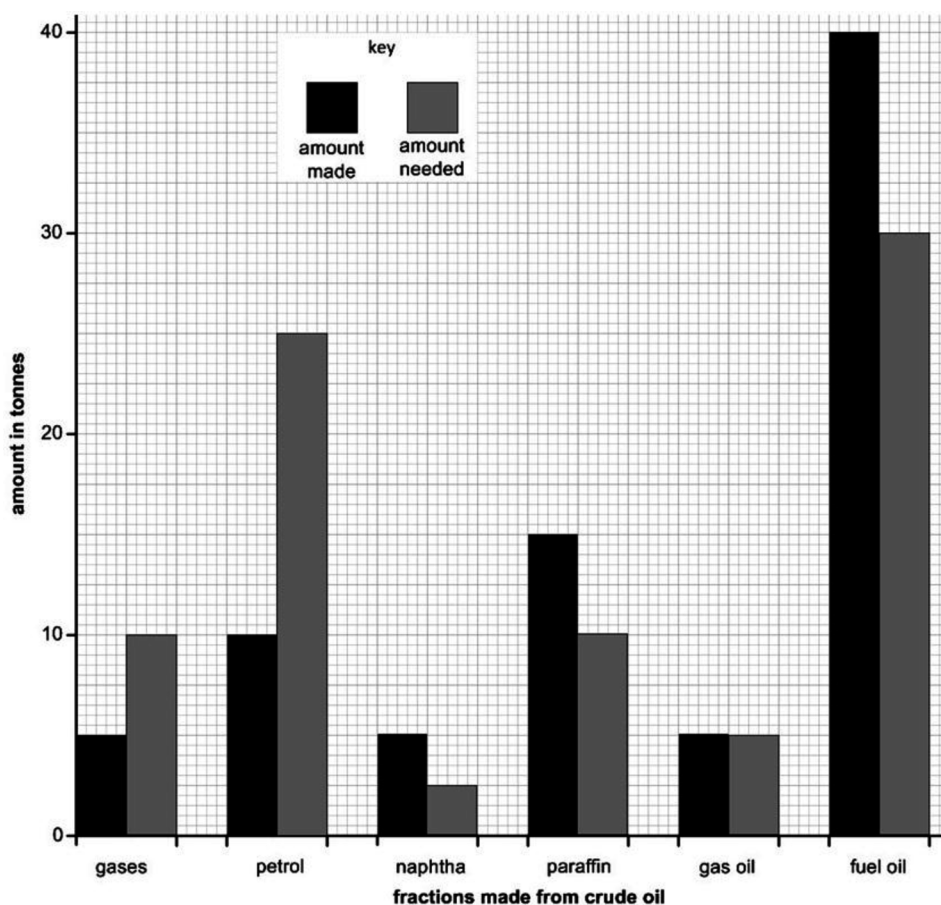

Cracking converts large molecules into smaller more useful molecules to make the supply match the demand.

Which fractions are most likely to be cracked to make the supply match the demand?

- A gas oil and fuel oil
- B gas oil and petrol
- C naphtha, paraffin and fuel oil
- D petrol and gases

Your answer

[1]

3 Urea,  $(\text{NH}_2)_2\text{CO}$ , is a fertiliser.

A student makes 1 mole of urea from 2 moles of ammonia.

What is the mass of urea that the student makes?

A 43.0 g

B 44.0 g

C 58.0 g

D 60.0 g

Your answer

[1]

4 A student is testing sodium carbonate solution.

She adds barium chloride solution followed by excess dilute hydrochloric acid.

Which of these observations would **not** be seen?

A colourless solution at the end

B gas bubbles when the dilute acid is added

C white precipitate formed when the barium chloride solution is added

D white precipitate formed when the dilute acid is added

Your answer

[1]

5 A student is making a fertiliser called potassium nitrate,  $\text{KNO}_3$ .

Look at the equation for the reaction she uses.



The relative formula masses,  $M_r$ , of each compound are shown in the table.

| Compound            | Formula              | Relative formula mass |
|---------------------|----------------------|-----------------------|
| potassium hydroxide | KOH                  | 56.1                  |
| nitric acid         | $\text{HNO}_3$       | 63.0                  |
| potassium nitrate   | $\text{KNO}_3$       | 101.1                 |
| water               | $\text{H}_2\text{O}$ | 18.0                  |

What is the atom economy for the reaction to make potassium nitrate?

Assume that water is a waste product.

- A 15.1%
- B 47.1%
- C 52.9%
- D 84.9%

Your answer

[1]

6 Which displayed formula includes the functional group of an alcohol?

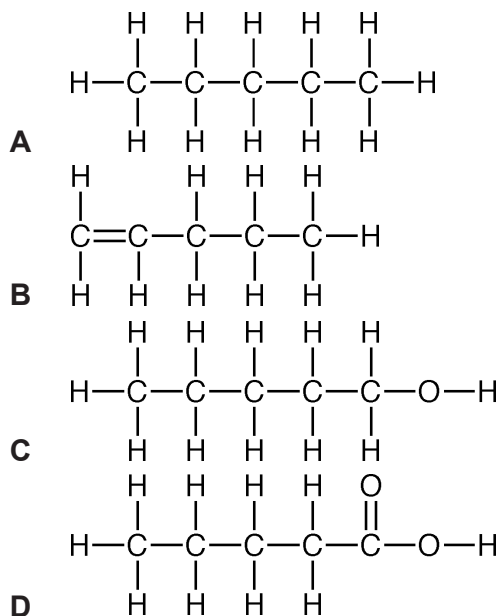

Your answer

[1]

7 Zinc nitrate thermally decomposes to give two gases.

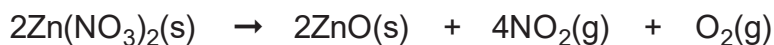

A student heats 1.89 g of zinc nitrate until there is no further reaction.

What is the **total** volume of gas measured at room temperature and pressure, made in this reaction?

- Assume that one mole of gas occupies a volume of  $24 \text{ dm}^3$  at room temperature and pressure.
- The molar mass of zinc nitrate is  $189 \text{ g/mol}$ .

**A**  $0.12 \text{ dm}^3$

**B**  $0.48 \text{ dm}^3$

**C**  $0.60 \text{ dm}^3$

**D**  $1.20 \text{ dm}^3$

Your answer

[1]

- 8 A student investigates the reaction between calcium carbonate and hydrochloric acid.

He measures the total volume of gas made every minute.

Look at the graph. It shows his results for the experiment.

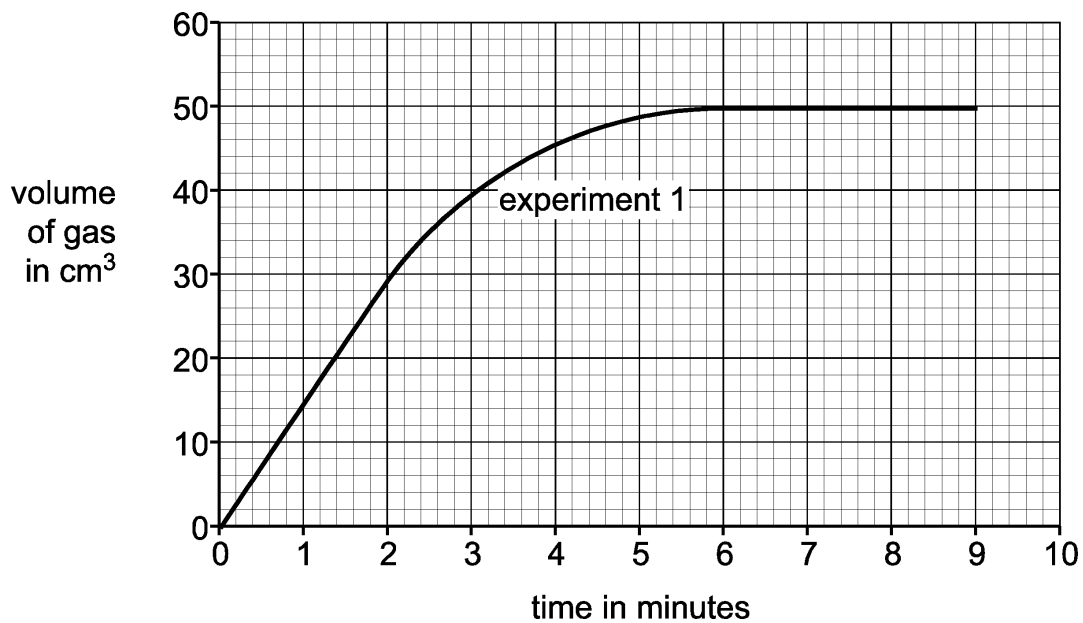

What is the rate of reaction between 0 and 2 minutes, in cm<sup>3</sup>/minute?

- A 7.5
- B 15
- C 30
- D 60

Your answer

[1]

- 9 A student investigates the reaction between 1.0 g of calcium carbonate and 20 cm<sup>3</sup> of 1.0 mol/dm<sup>3</sup> hydrochloric acid at 25 °C.

The student does two experiments.

- He uses **different** sized pieces of calcium carbonate for each experiment.
- The rate of reaction is greater in the first experiment.

Which is the best explanation for this result?

- A** Large pieces of calcium carbonate have a larger surface area resulting in less frequent collisions.
- B** Large pieces of calcium carbonate have a smaller surface area resulting in more frequent collisions.
- C** Small pieces of calcium carbonate have a larger surface area resulting in less frequent collisions.
- D** Small pieces of calcium carbonate have a larger surface area resulting in more frequent collisions.

Your answer

[1]

- 10 These statements explain how scientists think our modern-day atmosphere was formed.

- 1 Plants evolved and used carbon dioxide during photosynthesis to make oxygen.
- 2 As the Earth cooled down, water fell as rain resulting in the formation of the oceans.
- 3 The atmosphere today consists of nitrogen, oxygen and a small amount of carbon dioxide.
- 4 Volcanoes gave out ammonia and carbon dioxide as well as methane and water vapour.
- 5 Ammonia was changed by bacteria in the soil into nitrogen gas.

What is the correct order that these events happened?

- A** 1, 4, 2, 5, 3
- B** 2, 4, 5, 3, 1
- C** 4, 1, 5, 2, 3
- D** 4, 2, 5, 1, 3

Your answer

[1]



11 A student bubbles ethene gas into bromine water.

Which displayed formula shows the product of this reaction?

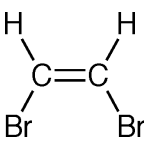
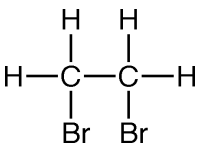
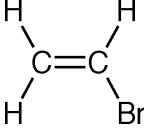
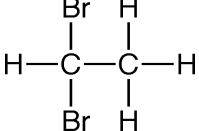
- A** 
- B** 
- C** 
- D** 

Your answer

[1]

12 Which procedure is the **most** suitable for preparing a 0.10 mol/dm<sup>3</sup> solution of sodium carbonate?

- The relative formula mass,  $M_r$ , of sodium carbonate is 106.
- A** Dissolving 10.6 g of sodium carbonate in water to make 1.0 dm<sup>3</sup> of solution.
- B** Dissolving 10.6 g of sodium carbonate in 0.10 dm<sup>3</sup> of water.
- C** Dissolving 10.6 g of sodium carbonate in 1.0 dm<sup>3</sup> of water.
- D** Dissolving 106 g of sodium carbonate in water to make 1.0 dm<sup>3</sup> of solution.

Your answer

[1]

- 13 A student reacts some metals with different salt solutions and records her results.

She places a tick (✓) in her results table if she sees a chemical change and a cross (X) if there is no reaction.

Some of the boxes are blanked out.

|           | Magnesium chloride | Silver nitrate | Copper(II) sulfate | Iron(II) sulfate |
|-----------|--------------------|----------------|--------------------|------------------|
| Magnesium |                    | ✓              | ✓                  | ✓                |
| Silver    | X                  |                | X                  | X                |
| Copper    | X                  | ✓              |                    | X                |
| Iron      | X                  | ✓              | ✓                  |                  |

Which metal has the **least** tendency to form a positive ion?

- A copper
- B iron
- C magnesium
- D silver

Your answer

[1]

- 14** A student heats compound **X** with acidified potassium manganate(VII) solution.  
The product of the reaction is compound **Y**.

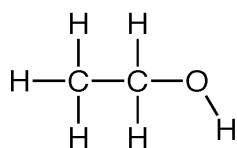
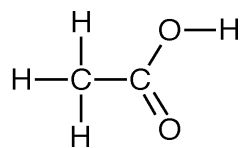
**X****Y**

What is the colour change seen during this reaction?

- A** colourless to orange  
**B** colourless to purple  
**C** orange to colourless  
**D** purple to colourless

Your answer

[1]

- 15** A condensation polymer is made from two monomers.

- One monomer has two –OH groups in its molecule.
- The other monomer has two –COOH groups in its molecule.

Which term describes the polymer?

- A** DNA  
**B** polyamide  
**C** poly(chloroethene)  
**D** polyester

Your answer

[1]

## SECTION B

Answer **all** the questions.

**16** Zinc and dilute sulfuric acid react to make hydrogen.



A student measures the rate of this reaction by measuring the **loss in mass** of the reaction mixture.

She finds that the change in mass is very small and difficult to measure.

**(a)** Draw a labelled diagram to show a **better way** of measuring the rate of this reaction.

[3]

**(b)** The reaction between zinc and dilute sulfuric acid is slow.

The student decides to try and find a catalyst for this reaction.

She tests four possible substances.

Each time she adds 0.5 g of the substance to 1.0 g of zinc and 25 cm<sup>3</sup> of dilute sulfuric acid.

Look at her table of results.

| Substance added            | Colour of substance at start | Colour of substance at end | Relative rate of reaction |
|----------------------------|------------------------------|----------------------------|---------------------------|
| no substance               |                              |                            | 1                         |
| calcium sulfate powder     | white                        | white                      | 1                         |
| copper powder              | pink                         | pink                       | 10                        |
| copper(II) sulfate powder  | blue                         | pink                       | 30                        |
| manganese(IV) oxide powder | black                        | black                      | 1                         |

- (i) It is important to do the reaction with **only** zinc and dilute sulfuric acid and no substance added.

Explain why.

.....  
..... [1]

- (ii) It is important to do all of the reactions with the same concentration of acid.

Explain why.

.....  
..... [1]

- (iii) Which of the substances could be a catalyst for the reaction between zinc and dilute sulfuric acid?

.....  
Explain your answer.

.....  
.....  
.....  
..... [2]

- (iv) There is **not** enough evidence to confirm which substance is a catalyst.

Suggest an extra piece of experimental evidence that could be collected to confirm which substance is a catalyst.

.....  
..... [1]

- (v) The student does the experiment with copper, zinc and dilute sulfuric acid again.

This time she uses a lump of copper rather than copper powder.

Predict, with reasons, the relative rate of reaction.

.....  
.....  
..... [2]

17 The Group 7 elements are known as the halogens.

The halogens have similar chemical properties.

Their physical properties vary with increasing atomic number.

(a) Look at the table of information about the halogens.

| Halogen  | Symbol | Atomic number | Molecular formula | Atomic radius (in pm) | Reaction of halogen with sodium iodide solution |
|----------|--------|---------------|-------------------|-----------------------|---|
| fluorine | F      | 9             | F <sub>2</sub>    | 64                    | Makes iodine and sodium fluoride                |
| chlorine | Cl     | 17            | Cl <sub>2</sub>   | 99                    | Makes iodine and sodium chloride                |
| bromine  | Br     | 35            | Br <sub>2</sub>   | 114                   | .....<br>.....<br>.....                         |
| iodine   | I      | 53            | I <sub>2</sub>    | 133                   | No reaction                                     |
| astatine | At     | 85            | .....             | .....                 | No reaction                                     |

(i) Predict the molecular formula and atomic radius of astatine.

Put your answers in the table.

[2]

(ii) Predict the reaction of bromine with sodium iodide solution.

Put your answer in the table.

[1]

(iii) Explain your answer to (ii) in terms of the reactivity of the halogens.

.....

..... [1]

(b) All halogens react with alkali metals to make a salt.

(i) All halogens have similar chemical reactions.

Explain why in terms of electronic structure.

.....  
..... [1]

(ii) Sodium reacts with bromine to make sodium bromide, NaBr.

Construct the **balanced symbol** equation for this reaction.

..... [2]

(iii) What is the formula of the product of the reaction between astatine and potassium?

..... [1]

18 Chemical tests are used to identify gases, anions and cations.

- A student has an unknown solution.
- She thinks that the solution contains copper(II) ions and bromide ions.

Describe the chemical tests she does to confirm the presence of these two ions in the solution.

.....  
.....  
.....  
.....  
.....  
.....  
.....  
..... [4]

- 19 A student does three titrations with dilute hydrochloric acid and potassium hydroxide solution.

Hydrochloric acid neutralises the alkali potassium hydroxide.

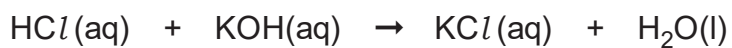

Look at the apparatus she uses.

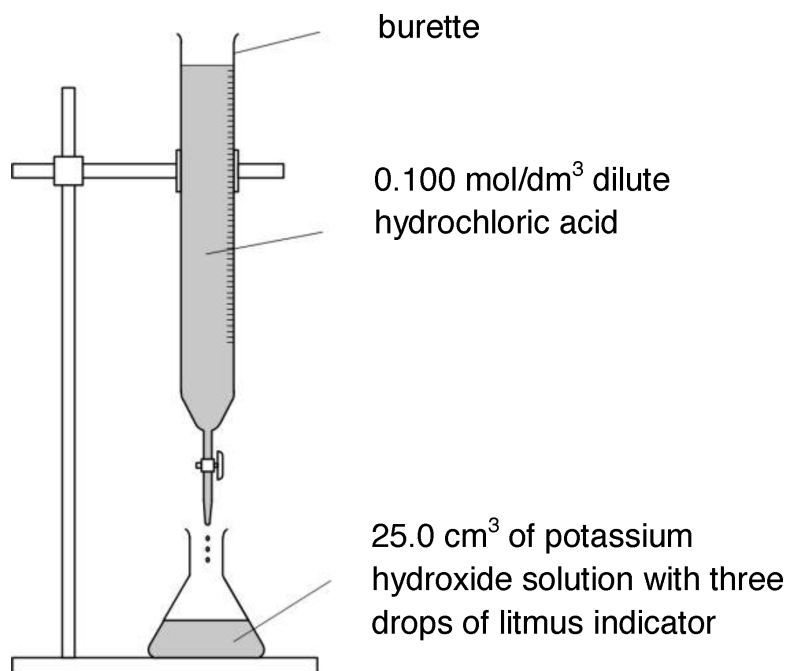

Look at the diagrams. They show parts of the burette during the first titration.

### First titration

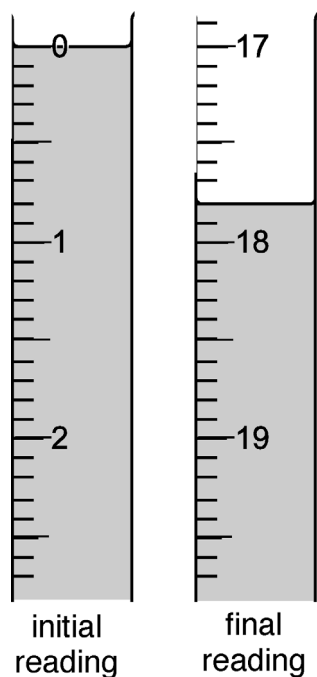



Here is the student's results table.

| Titration number                                | 1 | 2    | 3    |
|---|---|------|------|
| Final reading (cm <sup>3</sup> )                |   | 37.5 | 32.1 |
| Initial reading (cm <sup>3</sup> )              |   | 20.4 | 15.0 |
| Titre (volume of acid added) (cm <sup>3</sup> ) |   | 17.1 | 17.1 |

- (a) Using the diagrams and table, calculate the mean titre.

Explain your answer.

.....  
 .....

Answer = ..... cm<sup>3</sup> [2]

- (b) The student uses 25.0 cm<sup>3</sup> of potassium hydroxide solution, KOH.

She also uses hydrochloric acid with a concentration of 0.100 mol/dm<sup>3</sup>.

Calculate the concentration, in mol/dm<sup>3</sup>, of the KOH(aq).

Answer = ..... mol/dm<sup>3</sup> [2]

- (c) Use your answer to (b) to calculate the concentration of the KOH(aq) in g/dm<sup>3</sup>.

Answer = ..... g/dm<sup>3</sup> [2]



- 21 The reversible reaction between carbon dioxide and hydrogen makes methane and water.



- (a) In a sealed container, this reversible reaction forms a **dynamic equilibrium**.

What is meant by the term dynamic equilibrium?

Refer to both concentration and rate of reaction in your answer.

.....

.....

.....

..... [2]

- (b) A student investigates this reaction between carbon dioxide and hydrogen.

He predicts that 11.0 g of carbon dioxide should make 4.0 g of methane.

In an experiment, he finds that 11.0 g of carbon dioxide makes 2.2 g of methane.

Calculate the percentage yield of methane.

.....

.....

.....

Answer = ..... % [2]



22 Ammonium sulfate,  $(\text{NH}_4)_2\text{SO}_4$ , is a fertiliser.

Ammonium sulfate can be manufactured from ammonia and sulfuric acid.

(a) The Haber Process is used to manufacture ammonia.

Explain the importance of the Haber Process in agriculture.

.....  
.....  
..... [2]

(b) The Contact Process is used to manufacture sulfuric acid.

- The Contact Process involves the reaction between sulfur dioxide and oxygen.
- The conditions used are  $450^\circ\text{C}$  and about 10 atmospheres pressure.

(i) If the temperature is increased to  $500^\circ\text{C}$  the rate of reaction changes.

Describe and explain this change in rate of reaction.

.....  
.....  
..... [2]

(ii) If the pressure is reduced to 5 atmospheres the rate of reaction changes.

Describe and explain this change in rate of reaction.

.....  
.....  
.....  
..... [2]



23 Carbon dioxide is one of several greenhouse gases.

It is made by the combustion of fossil fuels such as coal, gas and oil.

Between 2010 and 2016, the total percentage increase of atmospheric carbon dioxide has been about 2.5%. During the same time, the increase in mean global temperature has been only 0.05 °C.

The table shows the amount of carbon dioxide produced in a large city in 2010 and 2016.

| Source of carbon dioxide | Carbon dioxide produced (tonnes) |           | Percentage increase (%) |
|--------------------------|----------------------------------|-----------|-------------------------|
|                          | in 2010                          | in 2016   |                         |
| Homes                    | 500 000                          | 600 000   | 20                      |
| Factories and industry   | 500 000                          | 750 000   | 50                      |
| Transport                | 1 000 000                        | 1 000 000 | 0                       |
| Electricity generation   | 750 000                          | 900 000   | .....                   |

(a) Look at the row for electricity generation.

Calculate the percentage increase of carbon dioxide produced.

Answer = ..... % [2]

(b) Some scientists think there is a link between the amount of fossil fuels burnt and climate change.

The data in the table does **not** support this view.

Suggest reasons why.

.....

.....

.....

..... [2]

24 A student investigates the corrosion of different metals.

- She places a small strip of each metal in different samples of air.
- She leaves the metals for one week before collecting her results.

Look at her table of results.

| Metal     | Original appearance of metal | Appearance of metal after one week in |                    |                  |                 |
|-----------|------------------------------|---------------------------------------|--------------------|------------------|-----------------|
|           |                              | moist acidic air                      | moist alkaline air | dry air          | moist air       |
| aluminium | shiny silver                 | dull silver                           | dull silver        | shiny silver     | shiny silver    |
| copper    | shiny red-orange             | dull red-orange                       | green red-orange   | shiny red-orange | dull red-orange |
| iron      | shiny silver                 | brown coating                         | brown coating      | shiny silver     | brown coating   |
| magnesium | shiny silver                 | whitish coating                       | dull silver        | shiny silver     | dull silver     |
| zinc      | shiny silver                 | dark coating                          | dark coating       | shiny silver     | dull silver     |

- (a) Suggest, with a reason, **one** change to the experimental procedure that would improve the quality of the results.

.....  
 ..... [1]

- (b) Explain the conclusions that can be made from her results.

.....  
 .....  
 .....  
 ..... [3]



25 Aluminium is extracted from its ore using electrolysis.

Copper is extracted from its ore by heating with carbon.

(a) Explain why different methods are used to extract aluminium and copper.

.....  
.....  
.....  
..... [2]

(b) Molten aluminium oxide contains  $Al^{3+}$  and  $O^{2-}$  ions.

The electrolysis of molten aluminium oxide makes aluminium and oxygen.

(i) Write the **balanced** half-equation for the reaction that happens at the cathode.

Use the symbol  $e^-$  to represent an electron.

..... [1]

(ii) Solid aluminium oxide **cannot** be electrolysed.

Explain why.

.....  
..... [1]

(c) Copper is also made by electrolysis of copper sulfate solution.

Look at the diagram of the apparatus used in this electrolysis.

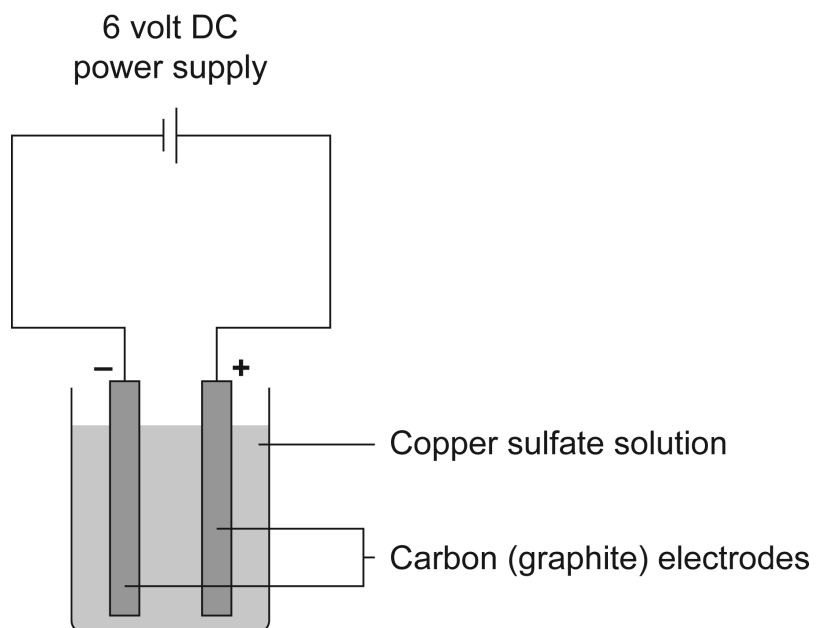

Describe what you would **see** at each electrode.

At the anode: .....

At the cathode: ..... [2]

26 Iron rusts when it gets wet.

(a) The word equation for rusting is

iron + water + oxygen → rust (hydrated iron(III) oxide)

Balance the symbol equation for the formation of rust.

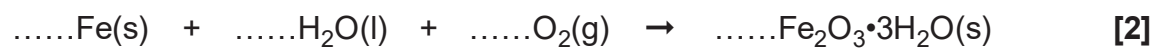

(b) A 1.0 kg iron bar is left outside in the rain.

- All of the iron turns to rust.
- The rust forms at a rate of 60 g per day.

Calculate how long it will take for the iron bar to turn completely to rust.

Give your answer to the nearest day.

Answer = ..... days **[6]**

**END OF QUESTION PAPER**

---

**OCR**

Oxford Cambridge and RSA

## Copyright Information

OCR is committed to seeking permission to reproduce all third-party content that it uses in its assessment materials. OCR has attempted to identify and contact all copyright holders whose work is used in this paper. To avoid the issue of disclosure of answer-related information to candidates, all copyright acknowledgements are reproduced in the OCR Copyright Acknowledgements Booklet. This is produced for each series of examinations and is freely available to download from our public website ([www.ocr.org.uk](http://www.ocr.org.uk)) after the live examination series.

If OCR has unwittingly failed to correctly acknowledge or clear any third-party content in this assessment material, OCR will be happy to correct its mistake at the earliest possible opportunity.

For queries or further information please contact OCR, The Triangle Building, Shaftesbury Road, Cambridge, CB2 8EA

OCR is part of the Cambridge Assessment Group; Cambridge Assessment is the brand name of University of Cambridge Local Examinations Syndicate (UCLES), which is itself a department of the University of Cambridge.