

Thursday 8 June 2017 – Morning

GCSE MATHEMATICS B

J567/04 Paper 4 (Higher Tier)

Candidates answer on the Question Paper.

OCR supplied materials:

None

Other materials required:

- Geometrical instruments
- Tracing paper (optional)
- Scientific or graphical calculator

Duration: 1 hour 45 minutes



Candidate forename		Candidate surname	
-----------------------	--	----------------------	--

Centre number						Candidate number				
---------------	--	--	--	--	--	------------------	--	--	--	--

INSTRUCTIONS TO CANDIDATES

- Write your name, centre number and candidate number in the boxes above. Please write clearly and in capital letters.
- Use black ink. HB pencil may be used for graphs and diagrams only.
- Answer **all** the questions.
- Read each question carefully. Make sure you know what you have to do before starting your answer.
- Your answers should be supported with appropriate working. Marks may be given for a correct method even if the answer is incorrect.
- Write your answer to each question in the space provided. Additional paper may be used if necessary but you must clearly show your candidate number, centre number and question number(s).
- Do **not** write in the barcodes.

INFORMATION FOR CANDIDATES

- The number of marks is given in brackets [] at the end of each question or part question.
- Your quality of written communication is assessed in questions marked with an asterisk (*).
- The total number of marks for this paper is **100**.
- This document consists of **20** pages. Any blank pages are indicated.

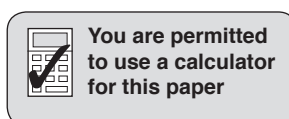

Formulae Sheet: Higher Tier

Area of trapezium = $\frac{1}{2}(a + b)h$

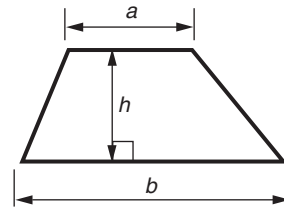

Volume of prism = (area of cross-section) \times length

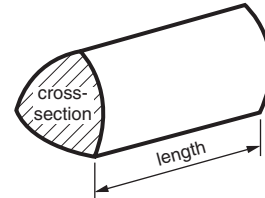

In any triangle ABC

Sine rule $\frac{a}{\sin A} = \frac{b}{\sin B} = \frac{c}{\sin C}$

Cosine rule $a^2 = b^2 + c^2 - 2bc \cos A$

Area of triangle = $\frac{1}{2}ab \sin C$

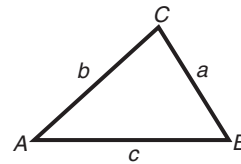

Volume of sphere = $\frac{4}{3}\pi r^3$

Surface area of sphere = $4\pi r^2$

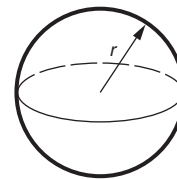

Volume of cone = $\frac{1}{3}\pi r^2 h$

Curved surface area of cone = $\pi r l$

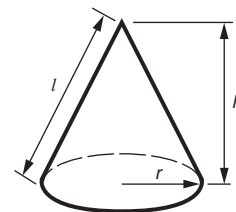

The Quadratic Equation

The solutions of $ax^2 + bx + c = 0$,
where $a \neq 0$, are given by

$$x = \frac{-b \pm \sqrt{b^2 - 4ac}}{2a}$$

PLEASE DO NOT WRITE ON THIS PAGE

Answer **all** the questions.

- 1 The diagram shows a storage chest.
It is in the shape of a prism.

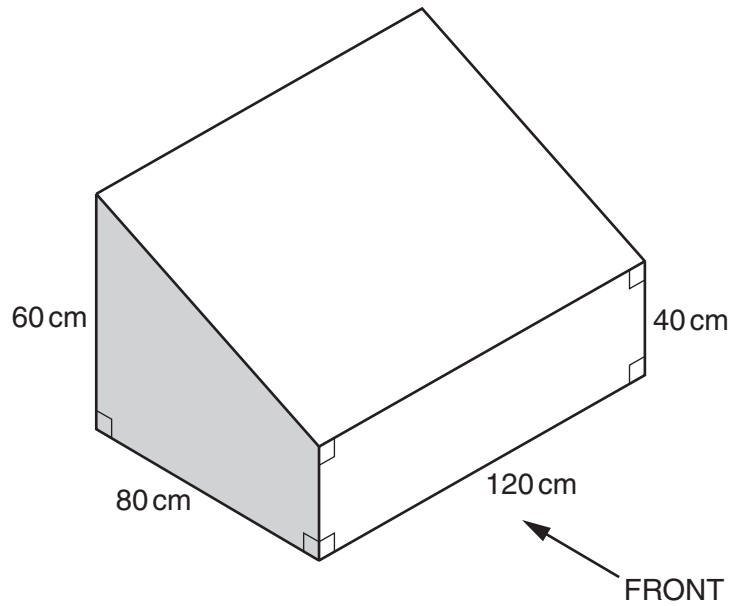

- (a) On the grid below, draw an accurate front elevation of the storage chest.
Use the scale **1 cm represents 20 cm**.

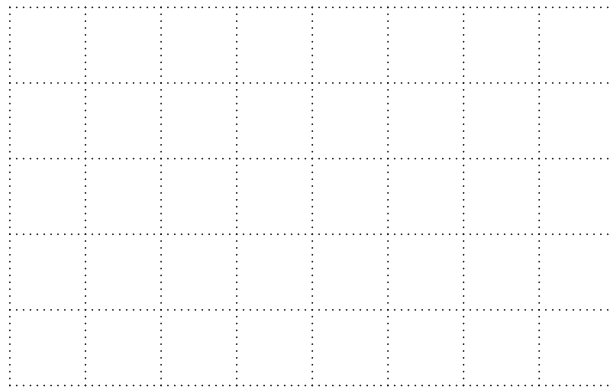

[2]

- (b) The shaded end of the chest is in the shape of a trapezium.

Calculate the volume, in cm^3 , of the chest.

(b) cm^3 [3]

- 2 Karl's Cars and City Cabs are two minicab companies.
The graph shows the amount charged by Karl's Cars to hire a minicab.

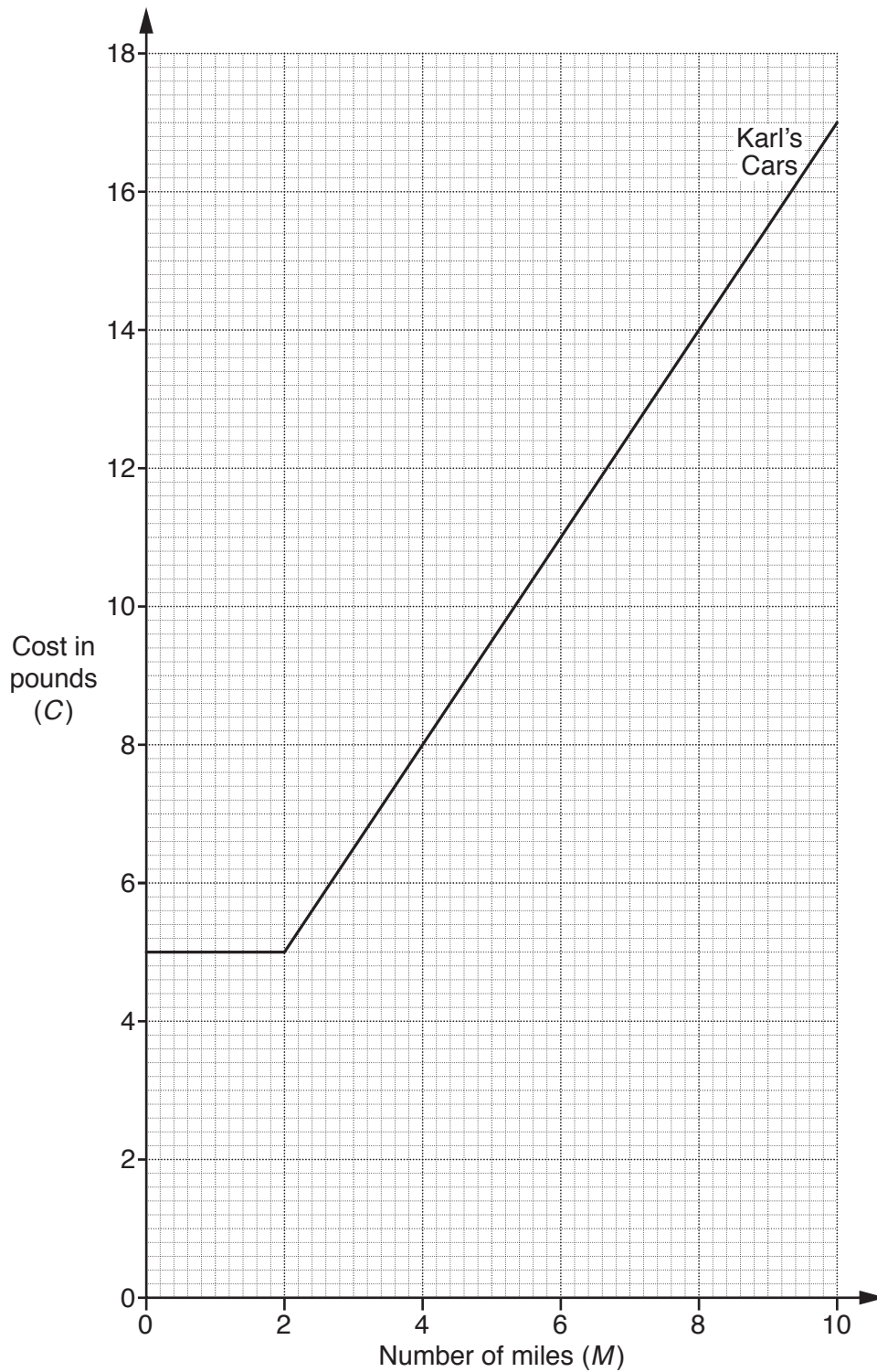

- (a) Complete the statement.

Karl's Cars charges a fixed rate of £5 for the first miles of a journey and then £ for each extra mile. [2]

(b) City Cabs uses this formula to work out the cost of hiring a minicab.

$$C = 3 + 1.3M$$

where C is the cost in pounds (£)
and M is the number of miles.

(i) Complete the table for $C = 3 + 1.3M$.

M	0	4	10
C			

[2]

(ii) Draw the graph of $C = 3 + 1.3M$ on the grid opposite.

[2]

(c) Jay needs a minicab for his 8 mile journey to work.

Which company is cheaper and by how much?

(c) is cheaper by £ [2]

3 Maha has a bag of sweets. The sweets are strawberry, blackcurrant, orange and lime. She takes one sweet from the bag at random. Some probabilities for this are shown in the table.

Sweet	strawberry	blackcurrant	orange	lime
Probability	0.36	0.25		0.18

(a) Find the probability that the sweet is orange.

(a) [2]

(b) Find the probability that the sweet is **not** lime.

(b) [1]

- 4 (a) Multiply out.

$$3(5 - 2t)$$

(a) [1]

- (b) Factorise fully.

$$10p^2 + 5p$$

(b) [2]

- 5 (a) Find the cube root of 5832.

(a) [1]

- (b) Find the reciprocal of 0.8.

(b) [1]

- (c) Write 675 as the product of its prime factors.

(c) [2]

- 6 A circular table has radius 0.85 m.

Calculate the area of the top of the table.

..... m² [2]

- 7 In the diagram below, lines PQR, STUV and WXYZ are parallel. QTX and QUY are also straight lines.

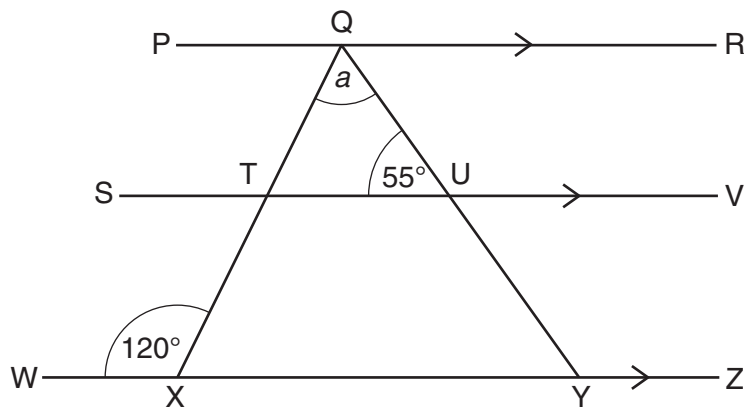

Not to scale

Work out angle a .
Give a reason for each step of your working.

..... ° [4]

8 Alex goes for regular cycle rides.

(a) The scatter diagram shows the distance cycled and time taken for some of his rides.

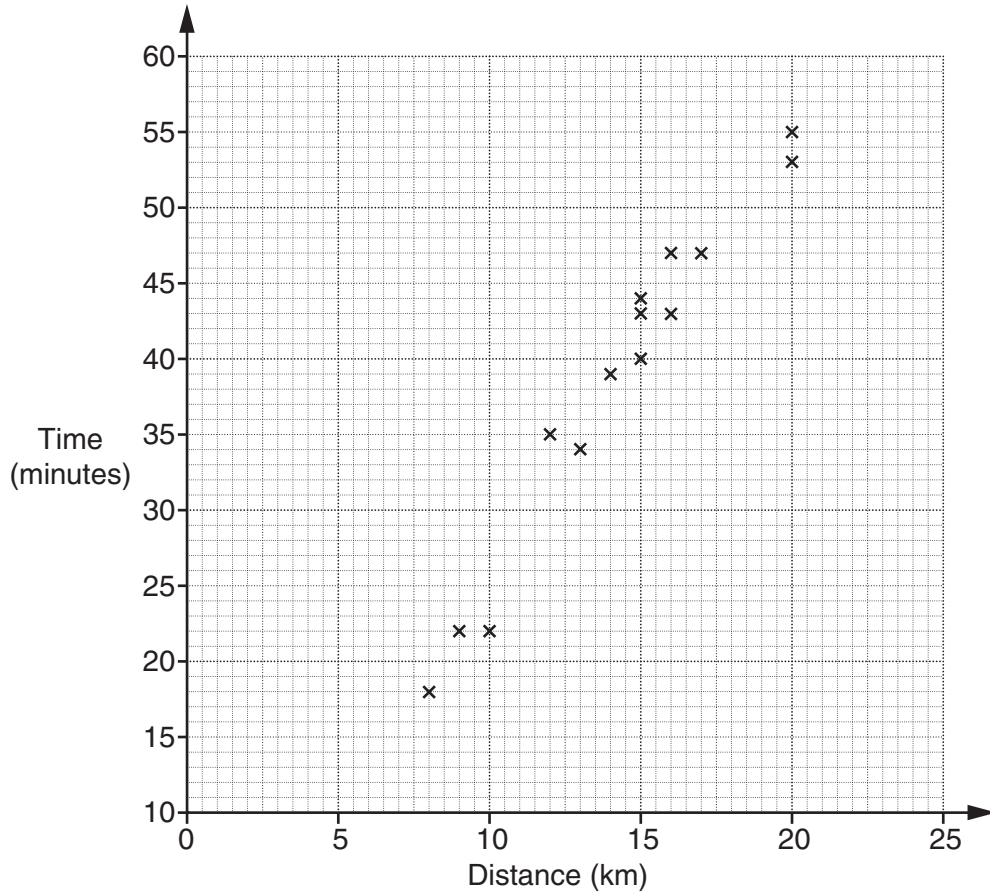

(i) Circle the **two** words below that describe the correlation shown.

positive negative zero weak strong moderate

[1]

(ii) Alex goes on another cycle ride.
It takes him 30 minutes.
He forgets to record the distance.

Draw a line of best fit on the scatter diagram and use it to estimate the distance Alex cycles.

(a)(ii) km [2]

(b) Alex goes on a 45 km cycle ride.
It takes him 2 hours 15 minutes.

Work out his average speed in kilometres per hour.

(b) km/h [3]

- 9 (a) Work out the value of $x^3 - 6x$ when $x = 3$.

(a) [1]

- (b) The equation $x^3 - 6x = 20$ has a solution between 3 and 4.

Find this solution correct to 1 decimal place.

Show all your trials and their outcomes in the table below.

x		

(b) $x =$ [3]

10

- 10* A vertical wall 1.6m high is on horizontal ground.
A ladder of length 2.5m rests against the wall.
The ladder rests on the ground 0.7m from the wall.

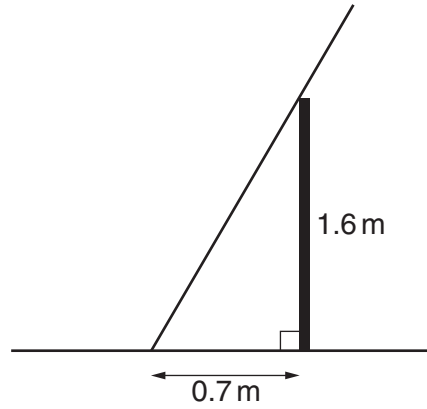

Not to scale

Work out the length of the ladder that extends above the wall.

..... [5]

11 (a) Solve the inequality.

$$4x - 3 > 7$$

(a) [2]

(b) Rearrange this formula to make q the subject.

$$p = \frac{q + 5}{2}$$

(b) [2]

(c) Solve.

$$\frac{5x + 2}{3} = 2x + 3$$

(c) $x =$ [3]

12 (a) Work out 247 as a percentage of 380.

(a) % [2]

(b) The price of a coat is reduced by 15% in a sale.
The sale price of the coat is £136.

Work out the price of the coat before the sale.

(b) £ [3]

13 Some points are marked on the grid.

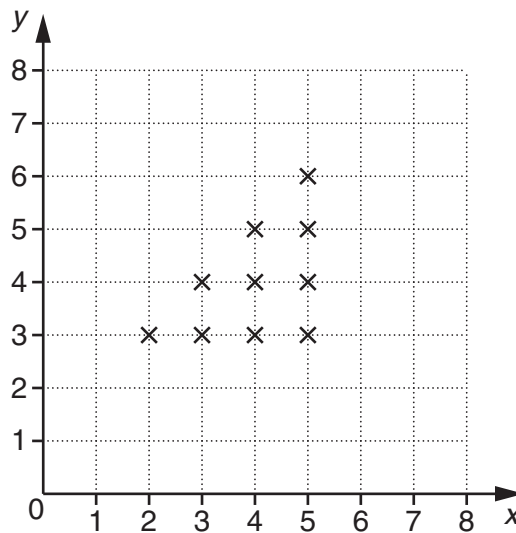

These points are the **only** points with integer coordinates that satisfy a set of inequalities.
Write down these three inequalities.

.....

 [3]

- 14 (a) C is the midpoint of the line AB.
 The coordinates of A are (3, -4).
 The coordinates of C are (5, -8).

Work out the coordinates of B.

(a) (.....,) [2]

- (b) The vectors \mathbf{p} and \mathbf{q} are shown on the grid.

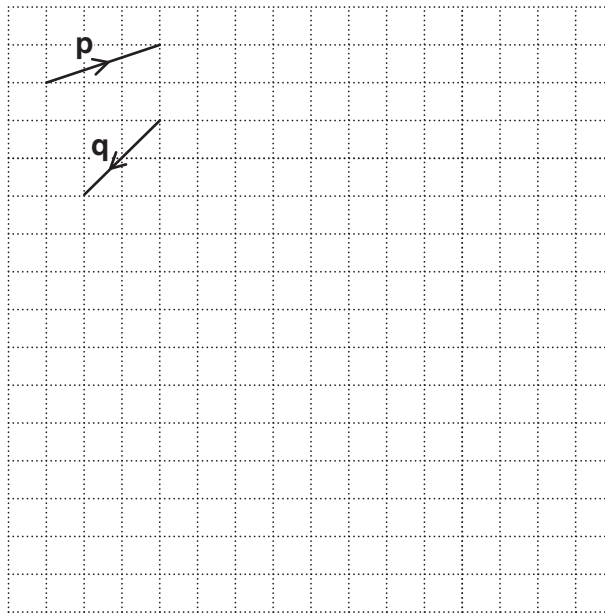

On the grid draw and label a vector

- (i) $3\mathbf{p}$, [1]
 (ii) $\mathbf{p} - \mathbf{q}$. [1]

15 (a) The table shows the amount of coal used in the UK for a number of years.

Year	Coal used (tonnes)
1980	1.24×10^8
1990	1.08×10^8
2000	5.99×10^7
2010	

(i) In 2010, the amount of coal used in the UK was 51.5 million tonnes.

Complete the table for 2010.

Write the amount of coal used in standard form.

[1]

(ii) How much more coal was used in 1990 than in 2000?

Give your answer in standard form.

(a)(ii) tonnes [2]

(b) The graph shows the amount of electricity generated in the UK between 1960 and 2010. It shows the amount generated from coal and the total amount generated from all fuels, measured in terawatt hours (TWh).

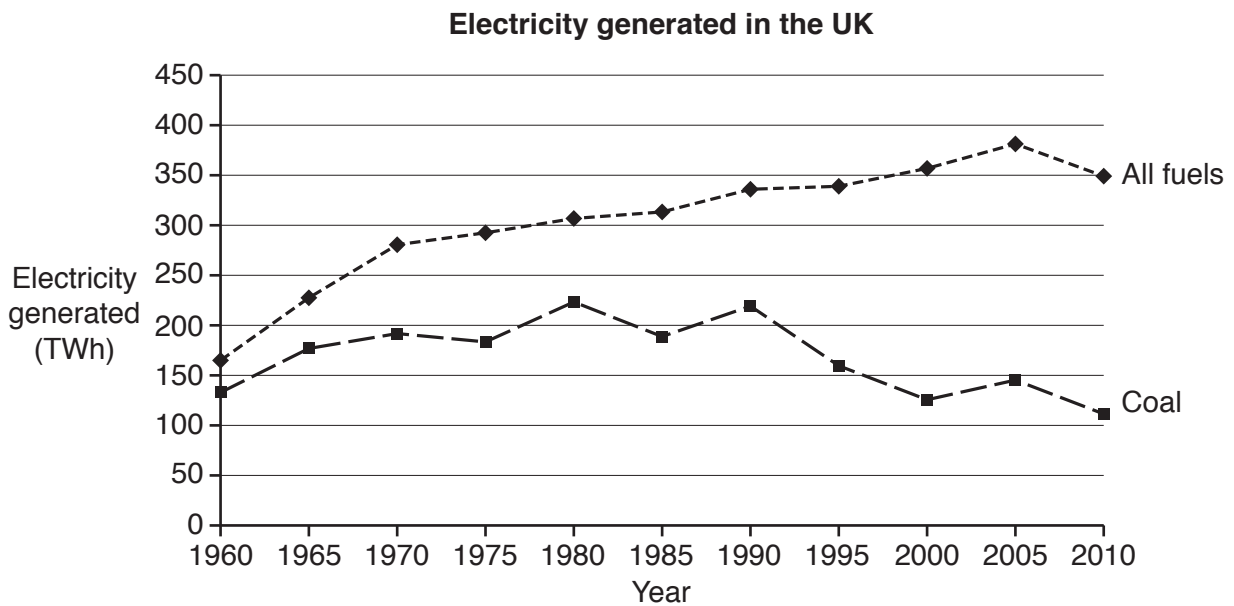

Make **two** comments comparing the amount of electricity generated from coal with the total amount of electricity generated from all fuels between 1960 and 2010.

1

.....

2.....

.....

[2]

- (c) The table shows the typical price of unleaded petrol in the UK each month in 2012. It also shows some four-monthly moving averages.

Month	Typical price (pence)	Moving average (pence)
January	133	
February	135	
March	138	137
April	142	138.25
May	138	137.5
June	132	135.75
July	131	A
August	134	B
September	139	135.5
October	138	136.5
November	C	136.25
December	133	

- (i) Calculate the two missing four-monthly moving averages, A and B.

(c)(i) A = p

B = p [2]

- (ii) Calculate the typical price of unleaded petrol in November, C.

(ii) C = p [2]

16 A bag contains coloured balls.
 A ball is taken at random from the bag, its colour is noted, and the ball is replaced.
 A second ball is taken at random from the bag, its colour is noted, and the ball is replaced.
 The probability that the ball is red is 0.2.

(a) Complete the tree diagram.

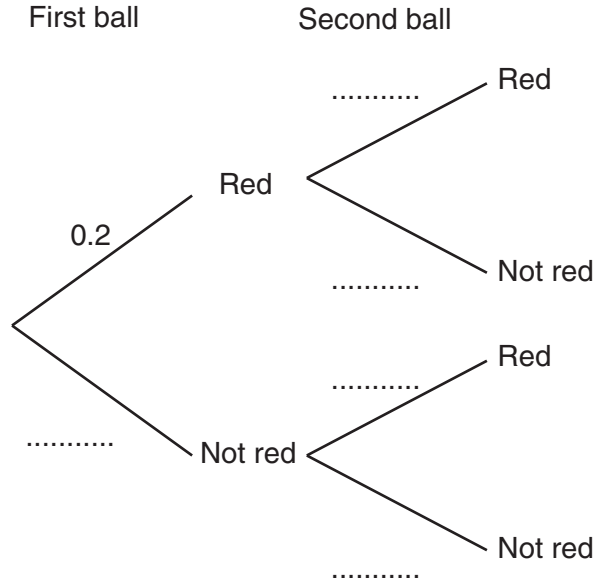

[1]

(b) Work out the probability that **only one** of the two balls taken is red.

(b) [3]

(c) A ball is taken at random from the bag, its colour is noted and the ball is replaced.
 This is done three times.

Find the probability that all three of the balls taken are red.

(c) [2]

- 17 (a) ABC is a right-angled triangle.
 AB = 7.5 cm and BC = 4.8 cm.

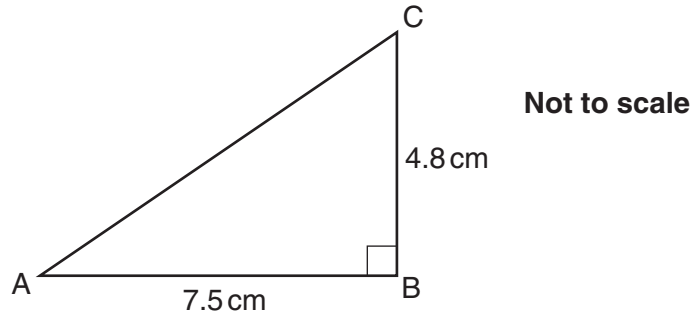

Calculate angle BAC.

(a) ° [3]

- (b) In the triangle below, angle PQR = 125°.
 PQ = 6.2 cm and QR = 9.3 cm.

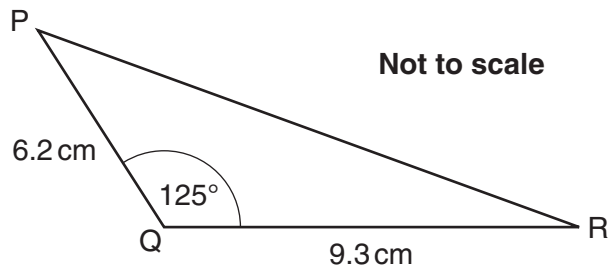

Calculate PR.

(b) cm [3]

- 18 Triangles ABE and ACD are similar.
 AB = 9 cm, BC = 6 cm and CD = 8 cm.

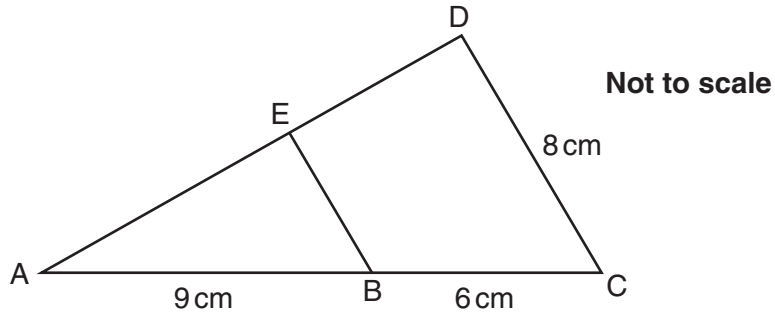

Work out BE.

..... cm [3]

- 19 A water tank contains 320 litres of water, correct to the nearest 10 litres.

(a) Write down the upper and lower bounds of the amount of water in the tank.

(a) upper bound = litres

lower bound = litres [2]

(b) 50 litres of water, correct to the nearest litre, are removed from the tank.

Calculate the upper bound of the amount of water left in the tank.

(b) litres [2]

20 Lee opened a savings account paying compound interest.
The amount, £ A , in the account t years after he first opened it is given by $A = 1500 \times 1.04^t$.

(a) Write down the amount of money that Lee used to open the account.

(a) £ [1]

(b) Write down the annual percentage interest rate for the account.

(b) [1]

(c) Lee decides to close his account when he has doubled his original amount of money.

At the end of how many years does he close the account?

(c) [2]

TURN OVER FOR QUESTION 21

21 Solve these simultaneous equations algebraically.

$$y = x^2 + 2x + 3$$

$$y = x + 6$$

Give your answers correct to 1 decimal place.

$$x = \dots\dots\dots y = \dots\dots\dots$$

$$x = \dots\dots\dots y = \dots\dots\dots[5]$$

END OF QUESTION PAPER