

Monday 09 November 2020 – Morning

GCSE (9–1) Mathematics

J560/06 Paper 6 (Higher Tier)

Time allowed: 1 hour 30 minutes



You can use:

- a scientific or graphical calculator
- geometrical instruments
- tracing paper



Please write clearly in black ink. **Do not write in the barcodes.**

Centre number

--	--	--	--	--

Candidate number

--	--	--	--

First name(s)

Last name

INSTRUCTIONS

- Use black ink. You can use an HB pencil, but only for graphs and diagrams.
- Write your answer to each question in the space provided. If you need extra space use the lined pages at the end of this booklet. The question numbers must be clearly shown.
- Answer **all** the questions.
- Where appropriate, your answer should be supported with working. Marks might be given for using a correct method, even if your answer is wrong.
- Use the π button on your calculator or take π to be 3.142 unless the question says something different.

INFORMATION

- The total mark for this paper is **100**.
- The marks for each question are shown in brackets [].
- This document has **24** pages.

ADVICE

- Read each question carefully before you start your answer.

Answer **all** the questions.

- 1 A travel agent records the duration and cost of the 15 flights he sold on one day. The data for the first 13 flights are plotted on the scatter diagram.

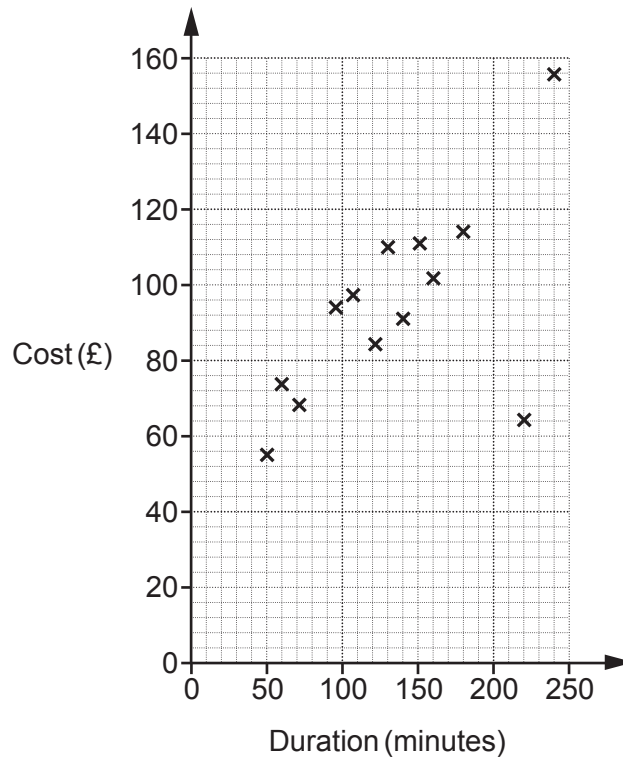

- (a) The data for the final two flights is:

Duration	210 minutes	1 hour 40 minutes
Cost	£130	£80

Plot these flights on the scatter diagram.

[2]

- (b) The cost of one of the 15 flights had been discounted in a sale.

Circle the most likely flight on the scatter diagram.

[1]

- (c) (i) Draw a line of best fit on the scatter diagram. [1]
- (ii) Use your line of best fit to estimate the duration of a flight costing £90.

(c)(ii) minutes [1]

- (d) Explain why the travel agent should not use his records to estimate the cost of a 7 hour flight.

.....

.....

..... [1]

- 2 Solve $3x + 4 < 19$.
Show your solution on the number line.

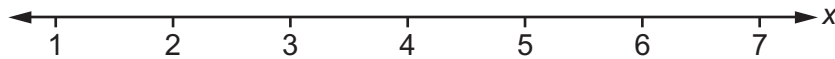

[4]

3 The graph shows the cost of electricity with Company A.

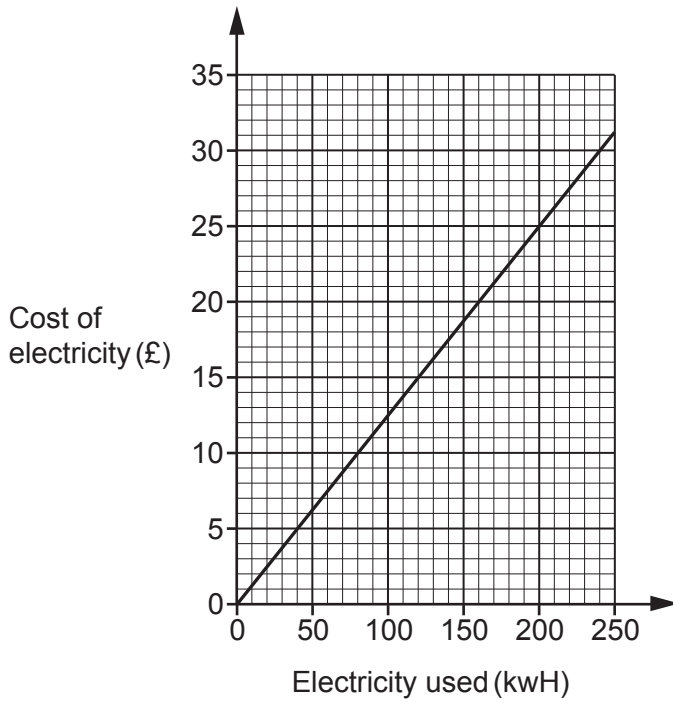

(a) Use the information in the graph to estimate the cost of electricity for a customer who uses 450 kWh of electricity.

(a) £ [3]

(b) Company B charges 14.3 pence per kWh of electricity used.

If Company B's cost of electricity was plotted on the same axes as Company A's cost of electricity, which line would be steeper?
Explain how you know.

Company would have the steeper line because

.....

..... [3]

4 Nina estimates the value of $\sqrt{\left(\frac{3.93 \times 393}{0.546 \times 220}\right)^3}$ by rounding each number to 1 significant figure.

(a) Show that Nina's answer is 64.

[3]

(b) Calculate the error in her estimated answer as a percentage of the exact answer.

(b) % [4]

5 (a) Work out the size of the exterior angle of a regular 12-sided polygon.

(a)° [2]

(b) Use your answer to part (a) to write down the size of the interior angle of a regular 12-sided polygon.

(b)° [1]

- 6 A truck is used to transport some wood panels.
Each wood panel is a cuboid measuring 2.4 m by 1.2 m by 1.8 cm.
The density of each wood panel is 750 kg/m^3 .

The truck can carry 15 tonnes of these wood panels.

Calculate the maximum number of wood panels that the truck can carry.
Show how you decide.

..... [6]

7 Vectors \mathbf{a} and $4\mathbf{b}$ are drawn on the grid.

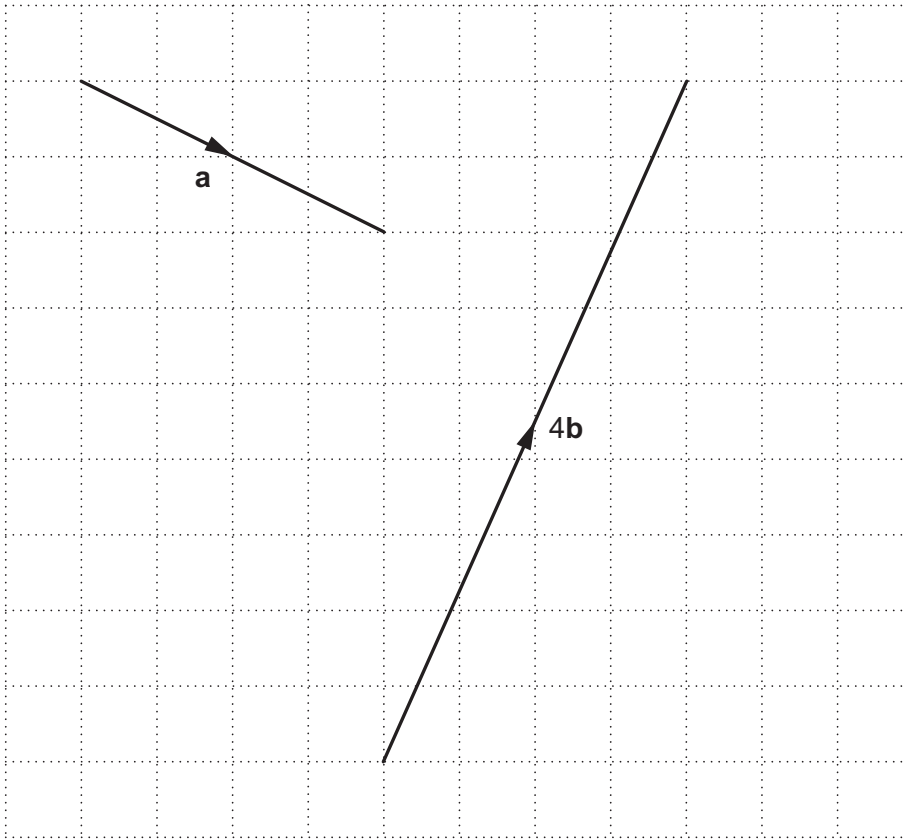

(a) Write vector \mathbf{a} as a column vector.

(a) $\begin{pmatrix} \\ \end{pmatrix}$ [2]

(b) Find vector \mathbf{b} as a column vector.

(b) $\begin{pmatrix} \\ \end{pmatrix}$ [2]

- 8 Li has t toy bricks.
She only has red bricks and blue bricks.

Li picks two bricks, one after the other.

If the first brick she picks is red, the probability that the second brick is red is $\frac{2}{3}$.

If the first brick she picks is blue, the probability that the second brick is red is $\frac{7}{10}$.

Calculate the value of t .

$t = \dots\dots\dots$ [4]

- 9 x is directly proportional to y .
 y is directly proportional to z .

When $x = 10$, $y = 60$.

When $y = 8$, $z = 1.6$.

Find a formula for z in terms of x .

..... [4]

- 10 Paintings are sold in an art gallery.
The cost of a painting has $k\%$ commission added to it.
Tax of 15% is then added to the total cost to give the price to pay.

Layla correctly calculates the price to pay by multiplying the cost of the painting by 1.403.

Work out the value of k .

$k = \dots\dots\dots$ [3]

11 Here are two functions.

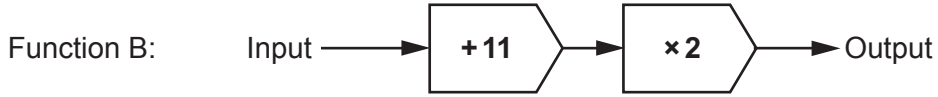
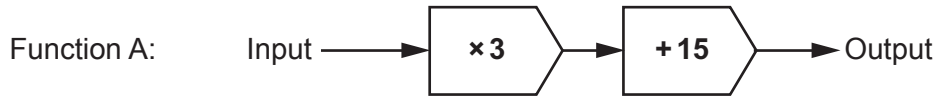

- (a) (i) Jo chooses a number, x .
 She inputs x into each function.
 The two outputs are equal.

Work out the value of x .

(a)(i) $x =$ [4]

- (ii) Explain why there is no other input that gives two outputs that are equal.

.....
 [1]

(b) Here is function C.

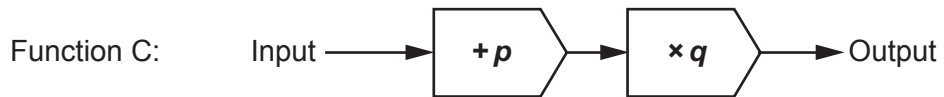

Kai chooses values for p and q so that if he inputs **any** number into both function A and function C, he will **always** get two outputs that are equal.

Find the value of p and the value of q .

(b) $p = \dots\dots\dots$
 $q = \dots\dots\dots$ [3]

12 Students are asked to choose one subject from Option A and one subject from Option B.

Option A	Option B
Economics Geography History Media Studies	Art Drama Engineering German Graphics Music PE

If a student chooses their subjects at random, what is the probability that both subjects have the same first letter?

..... [3]

- 13 In the diagram, AED and ABC are straight lines and BE is parallel to CD.

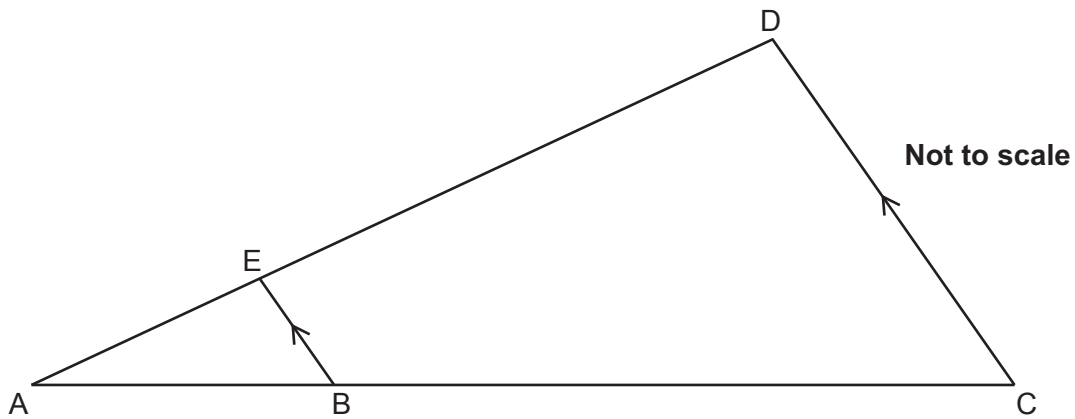

The ratio of length AB to length BC is 2 : 3.
 Triangle ABE has an area of 8 cm^2 .

Work out the area of triangle ACD.

..... cm^2 [4]

- 14 The base of a cone is fixed to the top of a cylinder to make a decoration.

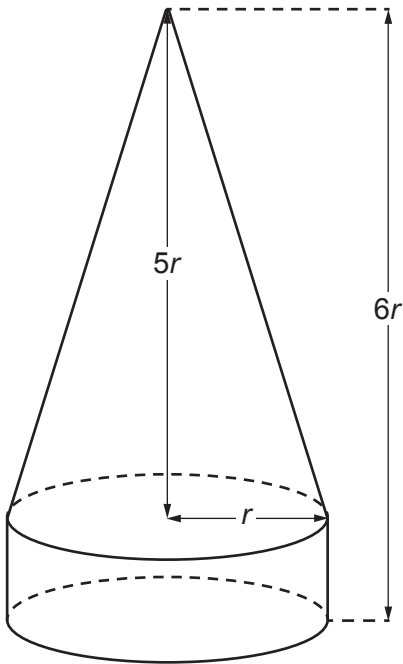

The radius of the base of the cone and of the cylinder is r cm.

The cone's height is $5r$ cm.

The total height of the decoration is $6r$ cm.

The total volume of the decoration is 225 cm^3 .

Calculate the value of r .

Show your working.

[The volume V of a cone with radius r and height h is $V = \frac{1}{3}\pi r^2 h$.]

$$r = \dots\dots\dots [5]$$

- 15** A bus company has a large number of buses.
25% of the buses are more than 10 years old.

If a bus is more than 10 years old, the probability that it will start first time is 0.3.
If a bus is less than 10 years old, the probability that it will start first time is 0.65.

Amir is asked to drive one of the company's buses, chosen at random.

Calculate the probability that the bus starts first time.

..... [4]

16 The diagram shows a circle, centre O.

Points A, B and C lie on the circumference of the circle.

Line AOB is a diameter.

Line DAE is a tangent to the circle.

Angle CAE = 32° .

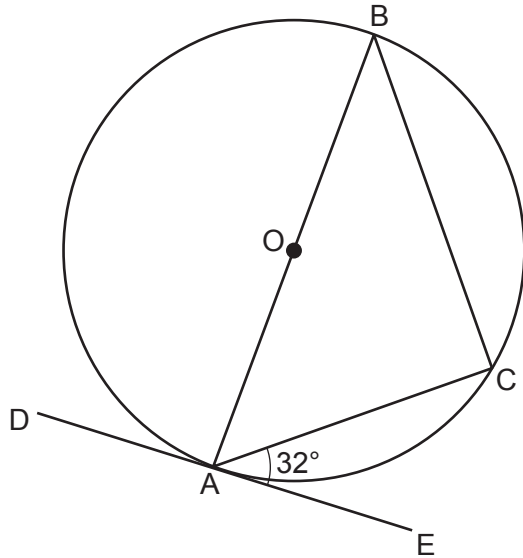

Not to scale

(a) Give a reason why angle ACB is a right angle.

.....
 [1]

(b) The radius of the circle is 8 cm.

Calculate length BC.

(b) cm [4]

17 Here is a sequence.

$$3 \quad 3\sqrt{5} \quad 15 \quad 15\sqrt{5}$$

(a) Work out the next term.

(a) [1]

(b) Find the n th term.

(b) [3]

18 Write $0.4\dot{1}\dot{6}$ as a fraction in its simplest form.
You must **show full working** in support of your answer.

..... [3]

19 The graph of $y = 2x^2 + 3x - 9$ is drawn below.

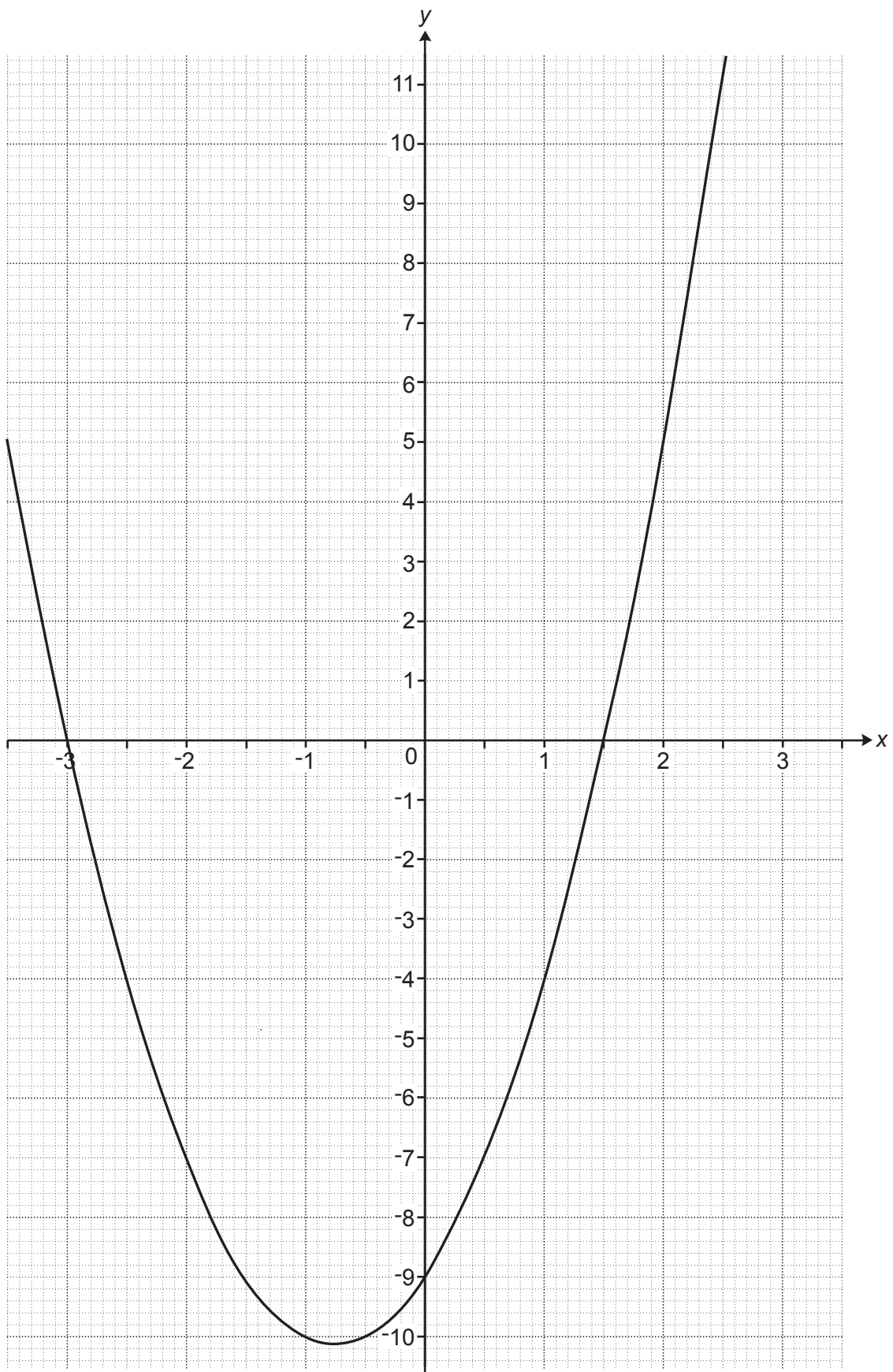

(a) Use the graph to solve $2x^2 + 3x - 9 = 0$.

(a) $x = \dots\dots\dots$ or $x = \dots\dots\dots$ [2]

(b) The equation $2x^2 + x - 4 = 0$ can be solved by finding the intersection of the graph of $y = 2x^2 + 3x - 9$ and the line $y = ax + b$.

(i) Find the value of a and the value of b .

(b)(i) $a = \dots\dots\dots$

$b = \dots\dots\dots$ [2]

(ii) Hence **use the graph** to solve the equation $2x^2 + x - 4 = 0$.

(ii) $x = \dots\dots\dots$ or $x = \dots\dots\dots$ [3]

20 Vector $\mathbf{m} = \begin{pmatrix} 2 \\ k \end{pmatrix}$ and vector $\mathbf{n} = \begin{pmatrix} 3 \\ 11 \end{pmatrix}$.

Vector $2\mathbf{m} + \mathbf{n}$ is parallel to $\begin{pmatrix} 1 \\ -1 \end{pmatrix}$.

Find the value of k .

$k = \dots\dots\dots$ [4]

21 Write as a single fraction in its simplest form.

$$\frac{x}{x+2} + \frac{x+1}{x-2} - \frac{6x}{x^2-4}$$

..... [6]

END OF QUESTION PAPER

ADDITIONAL ANSWER SPACE

If you need extra space use the following lined pages. The question numbers must be clearly shown.

A large rectangular area with horizontal dotted lines for writing, intended for providing additional answer space. A solid vertical line is on the left side, and a solid horizontal line is at the top.



Copyright Information

OCR is committed to seeking permission to reproduce all third-party content that it uses in its assessment materials. OCR has attempted to identify and contact all copyright holders whose work is used in this paper. To avoid the issue of disclosure of answer-related information to candidates, all copyright acknowledgements are reproduced in the OCR Copyright Acknowledgements Booklet. This is produced for each series of examinations and is freely available to download from our public website (www.ocr.org.uk) after the live examination series. If OCR has unwittingly failed to correctly acknowledge or clear any third-party content in this assessment material, OCR will be happy to correct its mistake at the earliest possible opportunity.

For queries or further information please contact The OCR Copyright Team, The Triangle Building, Shaftesbury Road, Cambridge CB2 8EA.

OCR is part of the Cambridge Assessment Group; Cambridge Assessment is the brand name of University of Cambridge Local Examinations Syndicate (UCLES), which is itself a department of the University of Cambridge.