

Write your name here

Surname

Other names

**Pearson Edexcel
International GCSE**

Centre Number

--	--	--	--	--

Candidate Number

--	--	--	--

Mathematics A

Paper 3H



Higher Tier

Thursday 24 May 2018 – Morning
Time: 2 hours

Paper Reference

4MA0/3H

You must have:

Ruler graduated in centimetres and millimetres, protractor, compasses, pen, HB pencil, eraser, calculator. Tracing paper may be used.

Total Marks

Instructions

- Use **black** ink or ball-point pen.
- **Fill in the boxes** at the top of this page with your name, centre number and candidate number.
- Answer **all** questions.
- Without sufficient working, correct answers may be awarded no marks.
- Answer the questions in the spaces provided
– *there may be more space than you need.*
- **Calculators may be used.**
- You must **NOT** write anything on the formulae page.
Anything you write on the formulae page will gain NO credit.

Information

- The total mark for this paper is 100.
- The marks for **each** question are shown in brackets
– *use this as a guide as to how much time to spend on each question.*

Advice

- Read each question carefully before you start to answer it.
- Check your answers if you have time at the end.

Turn over ►

P53342A

©2018 Pearson Education Ltd.

1/1/1



Pearson

**International GCSE MATHEMATICS
FORMULAE SHEET – HIGHER TIER**

Pythagoras' Theorem

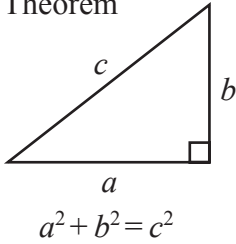

Volume of cone = $\frac{1}{3} \pi r^2 h$

Curved surface area of cone = $\pi r l$

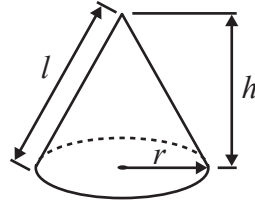

Volume of sphere = $\frac{4}{3} \pi r^3$

Surface area of sphere = $4 \pi r^2$

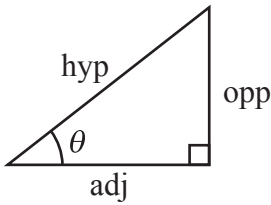
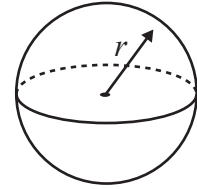

adj = hyp \times cos θ
opp = hyp \times sin θ
opp = adj \times tan θ

or $\sin \theta = \frac{\text{opp}}{\text{hyp}}$

$\cos \theta = \frac{\text{adj}}{\text{hyp}}$

$\tan \theta = \frac{\text{opp}}{\text{adj}}$

In any triangle ABC

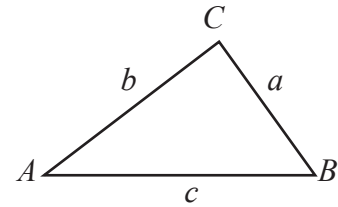

Sine rule: $\frac{a}{\sin A} = \frac{b}{\sin B} = \frac{c}{\sin C}$

Cosine rule: $a^2 = b^2 + c^2 - 2bc \cos A$

Area of triangle = $\frac{1}{2} ab \sin C$

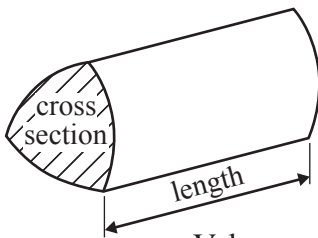

Volume of prism = area of cross section \times length

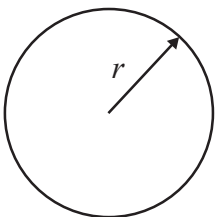

Circumference of circle = $2 \pi r$

Area of circle = πr^2

Area of a trapezium = $\frac{1}{2}(a + b)h$

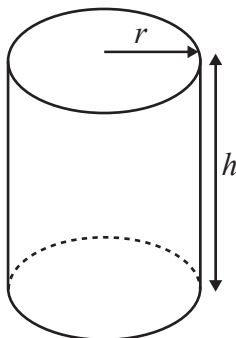
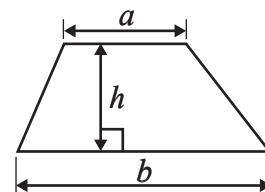

Volume of cylinder = $\pi r^2 h$

Curved surface area of cylinder = $2 \pi r h$

The Quadratic Equation

The solutions of $ax^2 + bx + c = 0$, where $a \neq 0$, are given by

$$x = \frac{-b \pm \sqrt{b^2 - 4ac}}{2a}$$



DO NOT WRITE IN THIS AREA

DO NOT WRITE IN THIS AREA

DO NOT WRITE IN THIS AREA

Answer ALL TWENTY ONE questions.

Write your answers in the spaces provided.

You must write down all the stages in your working.

1 (a) Work out the value of $\frac{56^2 + \sqrt{983}}{42.6 - 28.9}$

Write down all the figures on your calculator display.

.....
(2)

(b) Give your answer to part (a) correct to 2 significant figures.

.....
(1)

(Total for Question 1 is 3 marks)

2 The total cost of 8 calculators of the same type is £62.80

Work out the cost of 12 of these calculators.

£.....

(Total for Question 2 is 2 marks)



- 3 Steve goes on a cycle ride.
He cycles a distance of 40 km in 2 hours 15 minutes.
- (a) Work out his average speed in kilometres per hour.
Give your answer correct to the nearest whole number.

..... km/h
(3)

Steve's salary is \$28 500
He gets a salary increase of 2.4%

- (b) Work out Steve's salary after the increase.

\$.....
(3)

Nalini gets a salary increase of 3%
Her salary increase is \$702

- (c) Work out Nalini's salary before the increase.

\$.....
(3)

(Total for Question 3 is 9 marks)



4

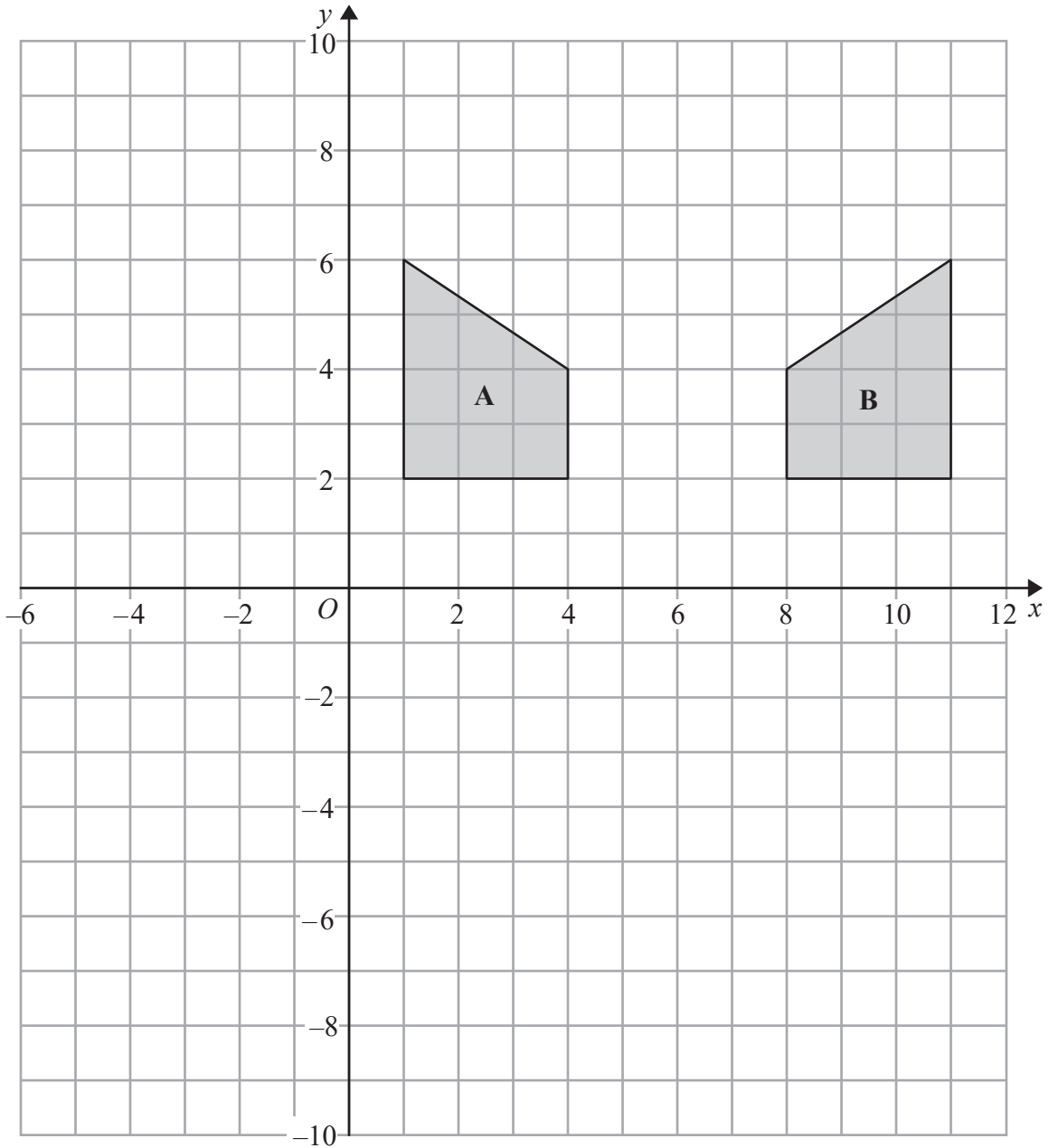

(a) Describe fully the single transformation that maps shape A onto shape B.

(2)

(b) On the grid, rotate shape A 180° about $(4, 0)$

(2)

(Total for Question 4 is 4 marks)



P 5 3 3 4 2 A 0 5 2 4

- 5 Here is a biased 5-sided spinner.

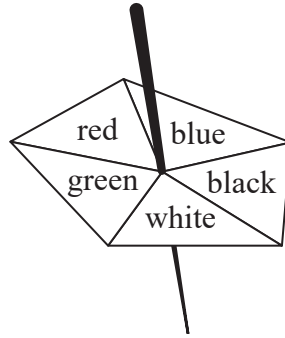

Jack spins the spinner once.

The table shows information about the probabilities that the spinner lands on red, on blue, on black, on white or on green.

Colour	red	blue	black	white	green
Probability	x	$2x$	$3x$	x	x

- (a) Work out the probability that the spinner lands on red.

.....
(3)

Malia spins the spinner 200 times.

- (b) Work out an estimate for the number of times the spinner lands on black.

.....
(2)

(Total for Question 5 is 5 marks)



6 (a) Factorise $m^2 + 7m$

.....
(1)

(b) Solve $7(x + 3) = 5x - 4$
Show clear algebraic working.

$x =$
(3)

(c) Expand and simplify $(y + 9)(y - 4)$

.....
(2)

(d) Simplify $(4e^{3f^2})^3$

.....
(2)

(Total for Question 6 is 8 marks)



7

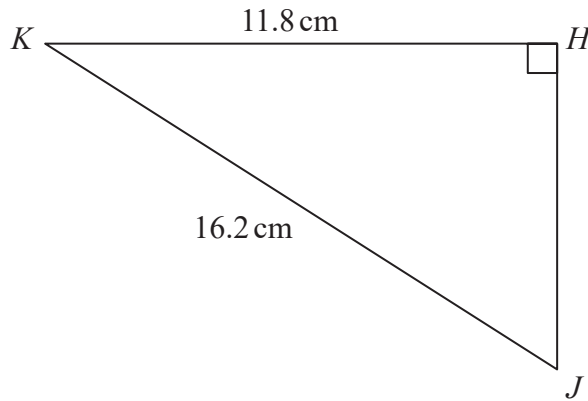

Diagram **NOT** accurately drawn

Calculate the length of HJ .
Give your answer correct to 3 significant figures.

.....cm

(Total for Question 7 is 3 marks)

DO NOT WRITE IN THIS AREA

DO NOT WRITE IN THIS AREA

DO NOT WRITE IN THIS AREA

8



DO NOT WRITE IN THIS AREA

DO NOT WRITE IN THIS AREA

DO NOT WRITE IN THIS AREA

8 (a) Solve the inequalities $-3 < x + 4 < 9$

.....
(2)

(b) On the number line, represent $-2 < y \leq 5$

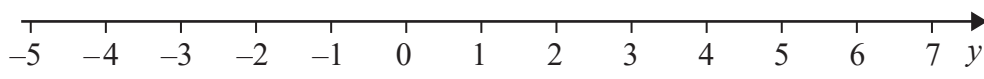

(2)

(Total for Question 8 is 4 marks)

9 (a) Write 82 000 000 in standard form.

.....
(1)

(b) Write 2.9×10^{-5} as an ordinary number.

.....
(1)

Jupiter has a mass of 1.898×10^{27} kg.

Mercury has a mass of 3.285×10^{23} kg.

The mass of Jupiter is k times the mass of Mercury.

(c) Work out the value of k .

Give your answer correct to 2 significant figures.

.....
(2)

(Total for Question 9 is 4 marks)



10 The table shows information about the weights of 60 apples.

Weight (w grams)	Frequency
$160 < w \leq 164$	12
$164 < w \leq 168$	20
$168 < w \leq 172$	14
$172 < w \leq 176$	7
$176 < w \leq 180$	4
$180 < w \leq 184$	3

(a) Write down the modal class.

.....grams
(1)

(b) Work out an estimate for the total weight of the 60 apples.

.....grams
(3)

(c) Using the table above, complete the cumulative frequency table.

Weight (w grams)	Cumulative frequency
$160 < w \leq 164$	
$164 < w \leq 168$	
$168 < w \leq 172$	
$172 < w \leq 176$	
$176 < w \leq 180$	
$180 < w \leq 184$	

(1)



DO NOT WRITE IN THIS AREA

DO NOT WRITE IN THIS AREA

DO NOT WRITE IN THIS AREA

(d) On the grid, draw a cumulative frequency graph for your table.

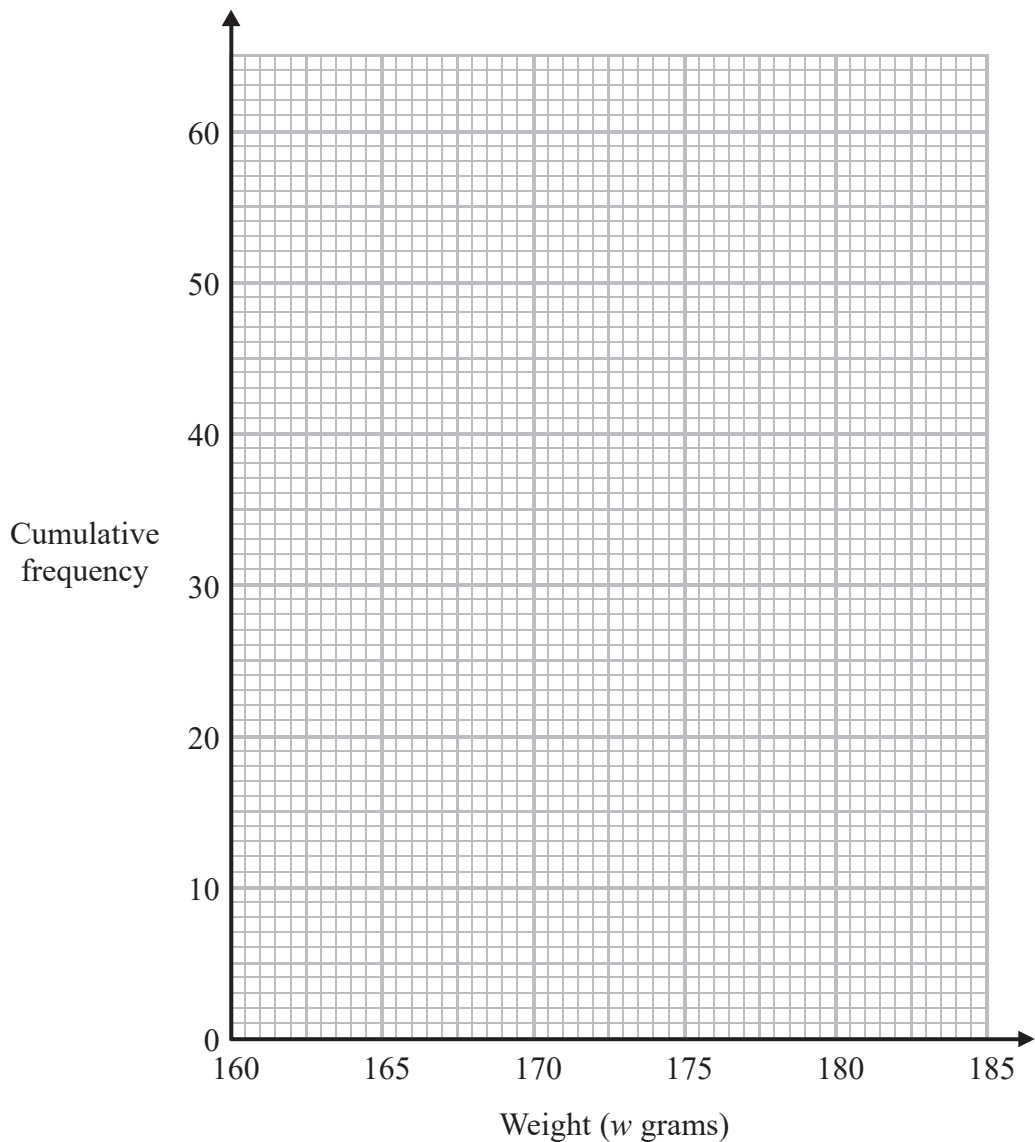

(2)

(e) Work out an estimate for the interquartile range.

.....grams

(2)

(Total for Question 10 is 9 marks)



P 5 3 3 4 2 A 0 1 1 2 4

11 Solve the simultaneous equations

$$7x - 2y = 41$$

$$4x + 3y = 11$$

Show clear algebraic working.

$$x = \dots\dots\dots$$

$$y = \dots\dots\dots$$

(Total for Question 11 is 4 marks)

DO NOT WRITE IN THIS AREA

DO NOT WRITE IN THIS AREA

DO NOT WRITE IN THIS AREA



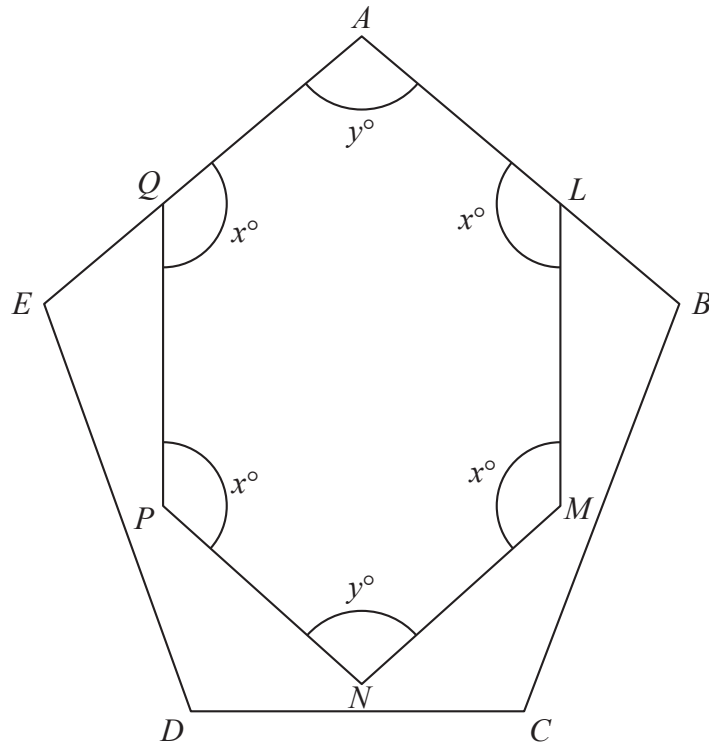

Diagram NOT accurately drawn

$ABCDE$ is a regular pentagon.

AQE and ALB are straight lines.

$ALMNPQ$ is a hexagon with two angles of size y° and four angles of size x°

Work out the value of x .

$x = \dots\dots\dots$

(Total for Question 12 is 4 marks)



- 13 Solve $4x^2 + 6x - 1 = 0$
Show your working clearly.
Give your solutions correct to 3 significant figures.

.....
(Total for Question 13 is 3 marks)

DO NOT WRITE IN THIS AREA

DO NOT WRITE IN THIS AREA

DO NOT WRITE IN THIS AREA



14

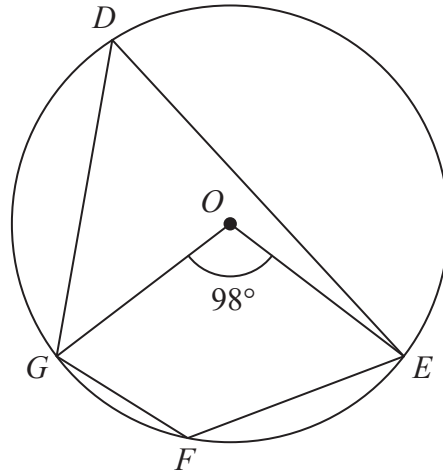

Diagram NOT accurately drawn

D , E , F and G are points on a circle, centre O .
 Angle $GOE = 98^\circ$

Work out the size of angle GFE .
 Give a reason for each stage of your working.

.....
 ○

(Total for Question 14 is 4 marks)

DO NOT WRITE IN THIS AREA

DO NOT WRITE IN THIS AREA

DO NOT WRITE IN THIS AREA



P 5 3 3 4 2 A 0 1 5 2 4

15 (a) Write $\frac{2}{x} - \frac{1}{x+3}$ as a single fraction in its simplest form.

DO NOT WRITE IN THIS AREA

DO NOT WRITE IN THIS AREA

DO NOT WRITE IN THIS AREA

(b) Simplify fully $\frac{9x^2 - 4}{3x^2 - 17x + 10}$

.....
(3)

.....
(3)

(Total for Question 15 is 6 marks)



16

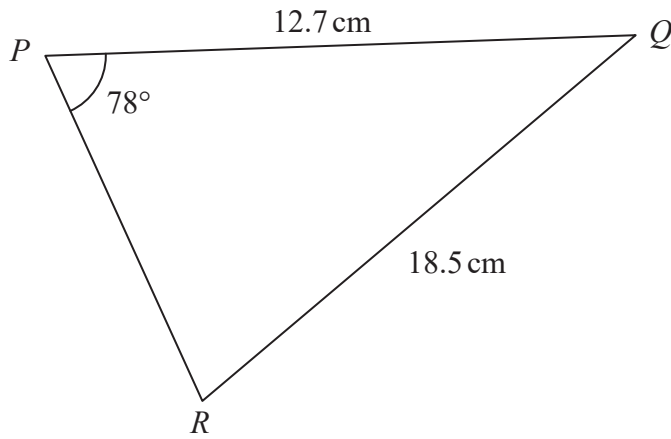

Diagram **NOT** accurately drawn

Work out the area of triangle PQR .
Give your answer correct to 3 significant figures.

..... cm^2

(Total for Question 16 is 4 marks)

DO NOT WRITE IN THIS AREA

DO NOT WRITE IN THIS AREA

DO NOT WRITE IN THIS AREA



17 Rationalise the denominator of $\frac{6 + \sqrt{10}}{\sqrt{2}}$

Give your answer in the form $a\sqrt{b} + \sqrt{c}$ where a , b and c are prime numbers.
Show your working clearly.

.....
(Total for Question 17 is 3 marks)

DO NOT WRITE IN THIS AREA

DO NOT WRITE IN THIS AREA

DO NOT WRITE IN THIS AREA



DO NOT WRITE IN THIS AREA

DO NOT WRITE IN THIS AREA

DO NOT WRITE IN THIS AREA

18 A particle moves along a straight line.

The fixed point O lies on this line.

The displacement of the particle from O at time t seconds ($t \geq 1$) is s metres, where

$$s = 3 + \frac{1}{t}$$

At time t seconds, the velocity of the particle is v m/s.

(a) Find an expression for v in terms of t .

$v = \dots\dots\dots$
(2)

(b) Find the acceleration of the particle at time 6 seconds.

$\dots\dots\dots \text{m/s}^2$
(2)

(Total for Question 18 is 4 marks)



- 19 The diagram shows a container made from a cylinder and a cone.
The container has a vertical axis of symmetry.

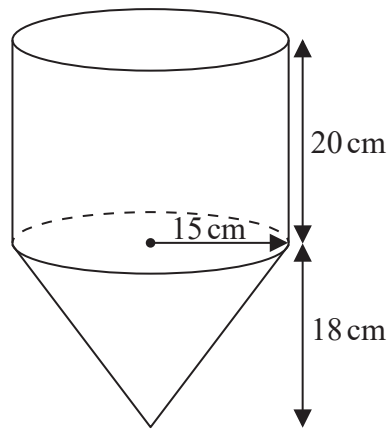

Diagram NOT
accurately drawn

The cylinder has height 20 cm and radius 15 cm.
The cone has height 18 cm and a base radius of 15 cm.

There are 9 litres of water in the container.

Work out the height of the surface of the water in the container above the vertex of the cone.
Give your answer correct to 3 significant figures.

.....cm

(Total for Question 19 is 5 marks)

DO NOT WRITE IN THIS AREA

DO NOT WRITE IN THIS AREA

DO NOT WRITE IN THIS AREA



- 20 There are 9 counters in a bag.
There is a number on each counter.



Lev takes at random 3 counters from the bag.
He adds together the numbers on his 3 counters to get his total.

Calculate the probability that his total is an odd number.

.....
(Total for Question 20 is 4 marks)



21 f is the function such that $f(x) = 3 - 2x$

(a) Find $f(-4)$

.....
(1)

(b) Express the inverse function f^{-1} in the form $f^{-1}(x) = \dots$

$f^{-1}(x) = \dots$
(2)

g is the function such that $g(x) = x^2 - 5$

(c) Solve the equation $gf(x) = ff(x)$
Show clear algebraic working.

.....
(5)

(Total for Question 21 is 8 marks)

TOTAL FOR PAPER IS 100 MARKS



DO NOT WRITE IN THIS AREA

DO NOT WRITE IN THIS AREA

DO NOT WRITE IN THIS AREA

BLANK PAGE

Do NOT write on this page.



P 5 3 3 4 2 A 0 2 3 2 4

DO NOT WRITE IN THIS AREA

DO NOT WRITE IN THIS AREA

DO NOT WRITE IN THIS AREA

BLANK PAGE

Do NOT write on this page.

