

Write your name here

Surname

Other names

**Pearson Edexcel**  
**Level 3 GCE**

Centre Number

--	--	--	--	--

Candidate Number

--	--	--	--

# Physics

**Advanced**

**Paper 1: Advanced Physics I**

Sample Assessment Materials for first teaching September 2015

**Time: 1 hour 45 minutes**

Paper Reference

**9PH0/01**

**You may need a calculator.**

Total Marks

## Instructions

- Use **black** ink or ball-point pen.
- **Fill in the boxes** at the top of this page with your name, centre number and candidate number.
- Answer **all** questions.
- Answer the questions in the spaces provided – *there may be more space than you need.*
- You may use a scientific calculator.

## Information

- The total mark for this paper is 90.
- The marks for **each** question are shown in brackets – *use this as a guide as to how much time to spend on each question.*
- In questions marked with an \*, marks will be awarded for your ability to structure your answer logically showing how the points that you make are related or follow on from each other where appropriate.

## Advice

- Read each question carefully before you start to answer it.
- Try to answer every question.
- Check your answers if you have time at the end.
- You are advised to show your working in calculations including units where appropriate.

Turn over ►

S47558A

©2015 Pearson Education Ltd.



**PEARSON**

**BLANK PAGE**

**Answer ALL questions.**

**All multiple choice questions must be answered with a cross ☒ in the box for the correct answer from A to D. If you change your mind about an answer, put a line through the box ☒ and then mark your new answer with a cross ☒.**

**1** Resistivity can be described correctly as

- A** resistance of a unit length.
- B** resistance per unit area.
- C** resistance per unit volume.
- D** resistance of a unit cube.

**(Total for Question 1 = 1 mark)**

**2** A capacitor of  $50 \mu\text{C}$  is charged to a potential difference of 12 V.

The energy stored on the charged capacitor in joules is given by

- A**  $0.5 \times 50 \times 10^{-6} \times 12^2$
- B**  $\frac{0.5 \times 50 \times 10^{-6}}{12^2}$
- C**  $\frac{0.5 \times 12^2}{50 \times 10^{-6}}$
- D**  $0.5 \times (50 \times 10^{-6})^2 \times 12$

**(Total for Question 2 = 1 mark)**

**3** A bullet is fired into a block of wood. Select the line of the table that applies to this situation.

	<b>Collision</b>	<b>Kinetic energy</b>	<b>Momentum</b>
<input type="checkbox"/> <b>A</b>	elastic	conserved	conserved
<input type="checkbox"/> <b>B</b>	inelastic	not conserved	conserved
<input type="checkbox"/> <b>C</b>	elastic	conserved	not conserved
<input type="checkbox"/> <b>D</b>	inelastic	not conserved	not conserved

**(Total for Question 3 = 1 mark)**

4 A ball is thrown upwards, allowed to fall and is caught.

The graph represents its motion.

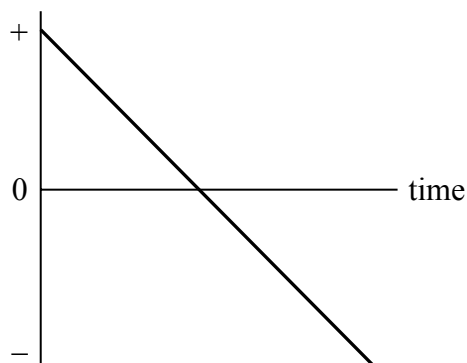

What quantity is plotted on the  $y$ -axis?

- A acceleration
- B displacement
- C speed
- D velocity

(Total for Question 4 = 1 mark)

5 Mains electricity in the UK is 230 V rms.

The peak voltage of the mains supply is given by

- A  $\frac{230}{\sqrt{2}}$  V
- B  $230\sqrt{2}$  V
- C  $\frac{\sqrt{2}}{230}$  V
- D  $\frac{230}{2}$  V

(Total for Question 5 = 1 mark)

- 6 The Large Hadron Collider is designed to accelerate protons to very high energies for particle physics experiments.

Very high energies are **not** required to

- A annihilate hadrons.
- B collide hadrons.
- C create particles with large mass.
- D create individual quarks.

(Total for Question 6 = 1 mark)

- 7 A potential difference,  $V$ , is applied to two resistors in parallel, each of resistance  $R$ . A current,  $I$ , flows through the whole circuit.

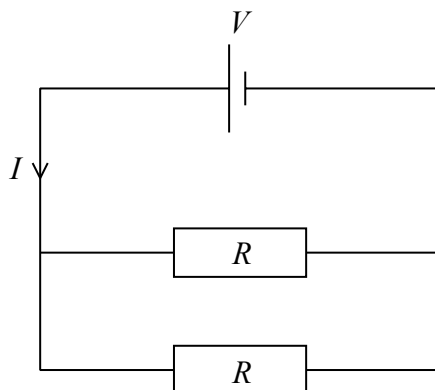

The correct expression for the power developed in each resistor is given by

- A  $P = IV$
- B  $P = IV/4$
- C  $P = V^2/2R$
- D  $P = I^2R/4$

(Total for Question 7 = 1 mark)

8 The joule can be expressed in SI base units as

- A  $\text{kg m s}^{-2}$
- B  $\text{kg m}^2 \text{s}^{-1}$
- C  $\text{kg m}^2 \text{s}$
- D  $\text{kg m}^2 \text{s}^{-2}$

(Total for Question 8 = 1 mark)

9 Which of these is **not** made from quarks?

- A proton
- B neutron
- C lepton
- D meson

(Total for Question 9 = 1 mark)

10 A picture with mass  $m$  hangs from a hook by a single length of wire. The hook is at the midpoint of the wire.

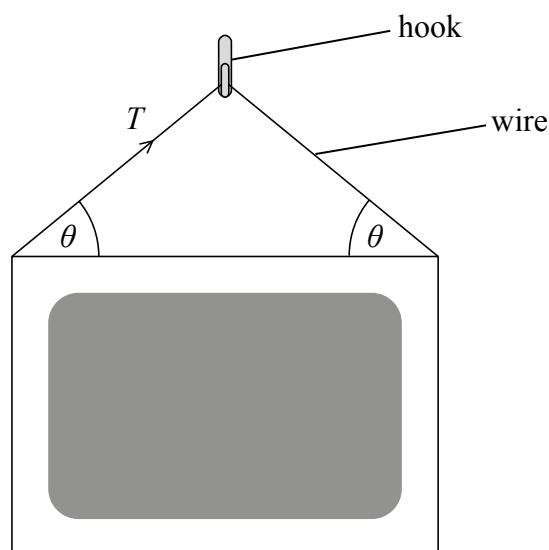

The tension  $T$  in the wire is given by

- A  $\frac{mg}{2\sin\theta}$
- B  $\frac{mg}{2\cos\theta}$
- C  $\frac{mg}{\sin\theta}$
- D  $\frac{mg}{\cos\theta}$

(Total for Question 10 = 1 mark)

**11** Rutherford's alpha-scattering experiment gave evidence that changed our understanding of the structure of the atom. Alpha particles were fired at a thin sheet of gold foil and their paths observed.

Explain how the observations of the different paths taken by the alpha particles as they passed through the gold foil led to a new model of the atom.

.....

.....

.....

.....

.....

.....

.....

.....

.....

.....

.....

.....

.....

.....

.....

.....

.....

.....

.....

.....

.....

.....

.....

**(Total for Question 11 = 4 marks)**

12 The diagram shows a diver of weight 680 N on a diving board.

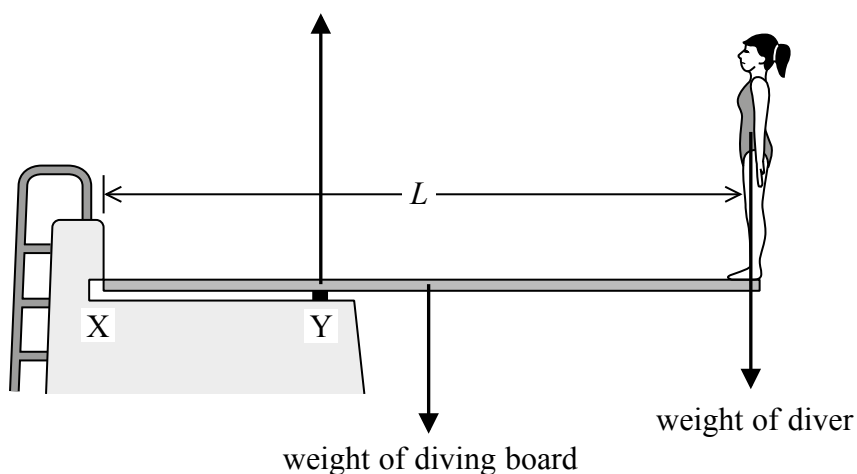

- (a) The diving board has a length  $L$  of 3.6 m and is fixed at the end labelled X. It is supported at position Y which is 0.9 m from X. The diving board is uniform and has a weight of 390 N.

By taking moments about X, determine the upward force exerted by the support at Y on the diving board.

(5)

Force = .....



(b) The free-body force diagram for the diver standing on the board is shown.

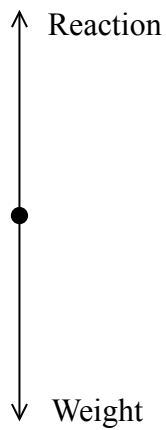

The two forces shown do **not** form a Newton third law pair.

Give **two** reasons why.

(2)

.....

.....

.....

.....

**(Total for Question 12 = 7 marks)**

- 13 A thermistor can be used to control a heater. When the temperature falls below a certain value the heater is switched on. The thermistor is connected in series with a fixed resistor  $R$  in a potential divider circuit as shown.

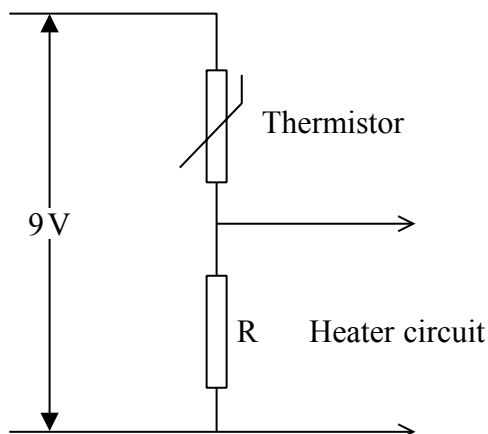

The heater circuit is connected across  $R$  and will switch on when the potential difference across it is above 5.5 V.

The variation of resistance of the thermistor  $R_T$  with temperature is shown on the graph.

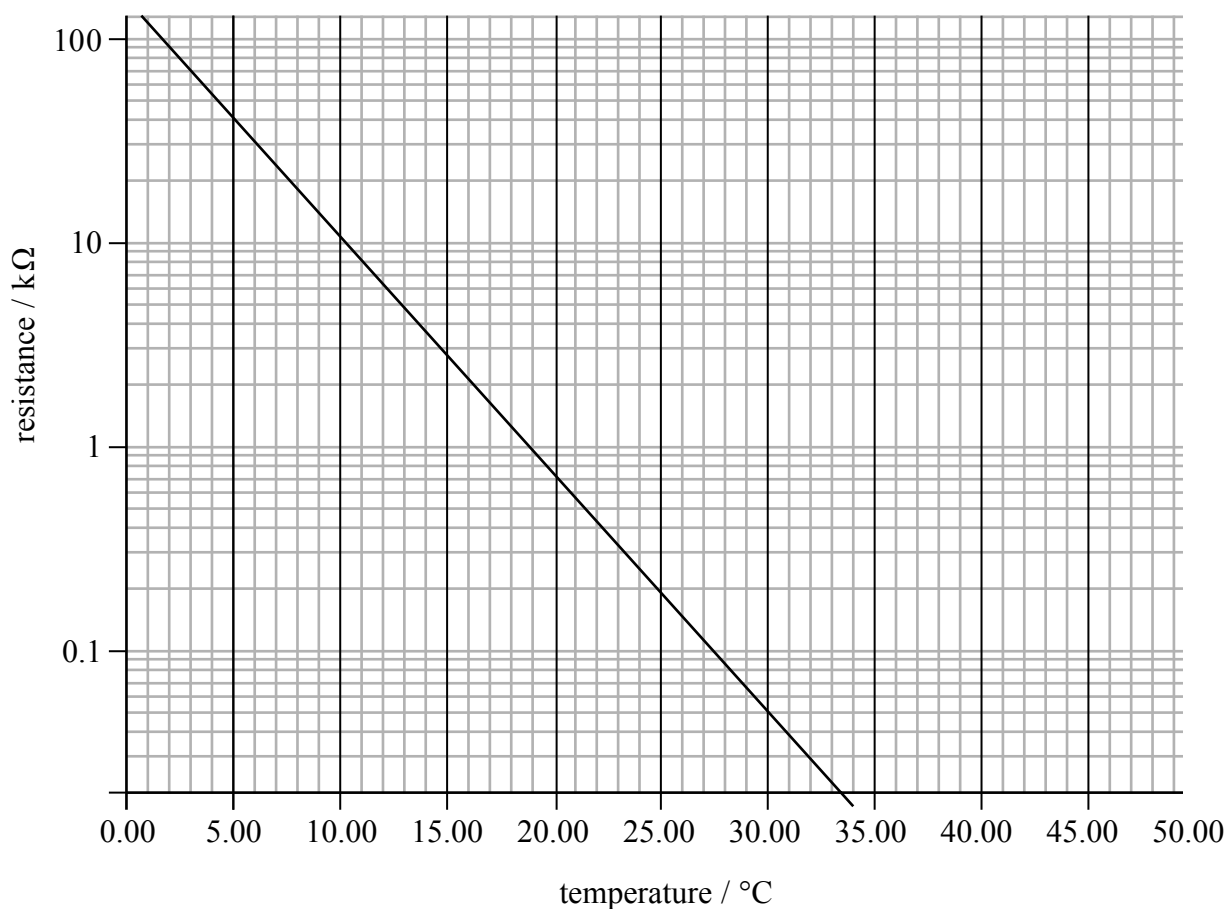

(Source: <http://reviseomatic.org/help/e-resistors/ThermistorLogGraph.gif>)

(a) With reference to charge carriers, explain why the resistance of the thermistor  $R_T$ , changes with temperature.

(2)

.....

.....

.....

.....

(b) The heater switches on when the temperature falls below  $20\text{ }^\circ\text{C}$ .

Calculate the resistance of the fixed resistor  $R$ .

(3)

.....

.....

.....

.....

.....

Resistance = .....

**(Total for Question 13 = 5 marks)**

14 A tennis player uses a racket to hit a ball over a net.

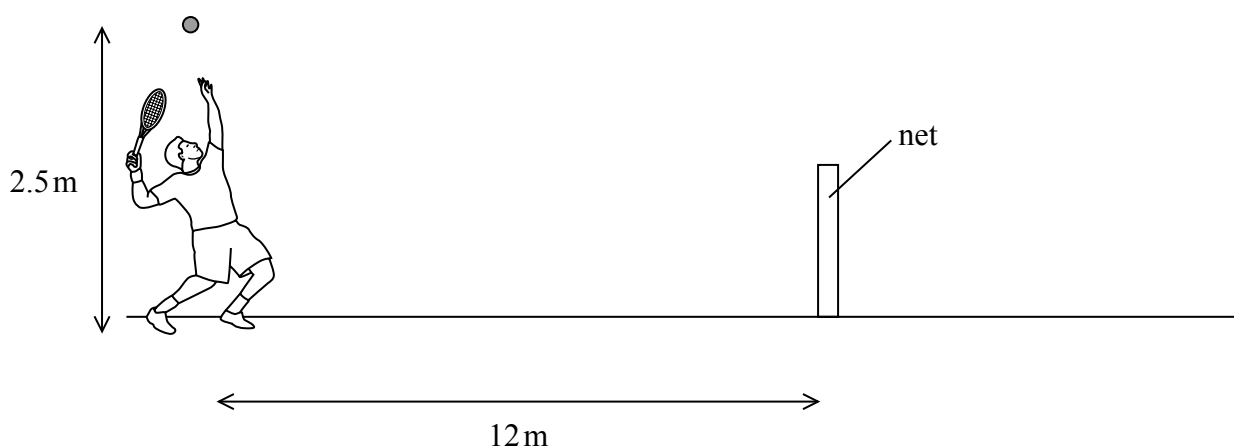

The player stands 12 m from the net. He throws the ball vertically upwards and hits the ball at a height of 2.5 m above the ground. The ball leaves the racket **horizontally** with a velocity of  $25 \text{ m s}^{-1}$ . The ball has a mass of 0.06 kg.

(a) The ball is in contact with the racket for 0.04 s.

Calculate the average force on the ball.

(3)

.....

.....

.....

.....

.....

Average force = .....



15 In an experiment to determine the charge on an electron, negatively charged oil drops are allowed to fall between two parallel metal plates separated by a distance  $d$ .

A potential difference (p.d.) is applied across the plates. The diagram shows one oil drop between the plates.

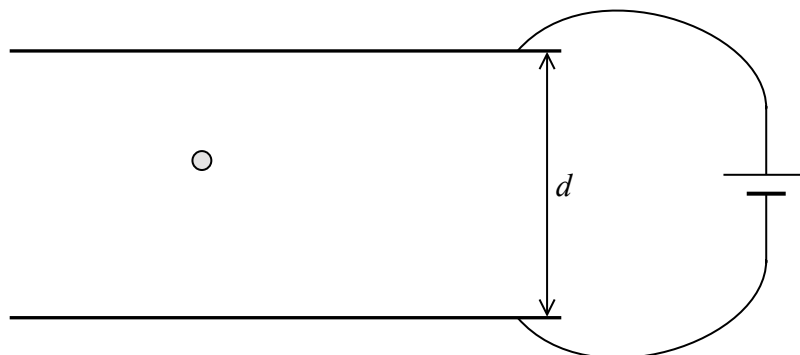

When the p.d. is 0 V the oil drop accelerates to terminal velocity. The p.d. is increased. It is observed that at a particular p.d.  $V$  the oil drop stops falling and remains stationary between the plates.

\*(a) Explain the motion of the oil drop in terms of the forces acting on it as the p.d. is increased from 0 to  $V$ .

(6)

.....

.....

.....

.....

.....

.....

.....

.....

.....

.....

.....

.....

.....

.....

.....

.....

.....

.....

.....

.....

.....

.....

(b) The oil drop has a mass  $m$ . Show that the charge  $q$  on the oil drop is given by

$$q = \frac{mgd}{V} \quad (2)$$

.....

.....

.....

(c) Explain what would happen to the oil drop if the p.d. is increased further. (2)

.....

.....

.....

.....

**(Total for Question 15 = 10 marks)**

---

**BLANK PAGE**





(b) When fully charged the battery has an e.m.f. of 6 V.

When the toothbrush is in use, the battery supplies a current of 57 mA with a terminal p.d. of 2.7 V to a motor.

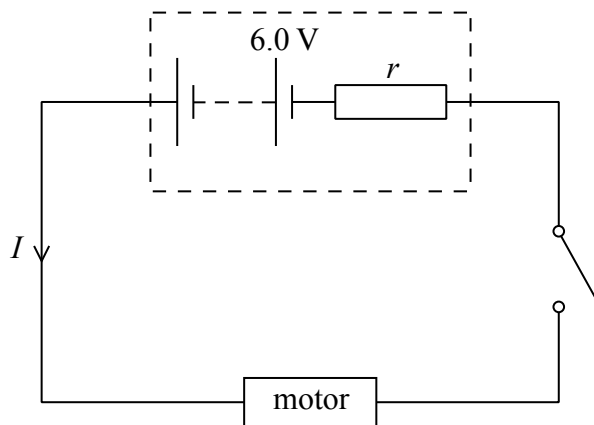

(i) Show that the resistance of the motor  $R$  is about 50  $\Omega$ .

(1)

.....

.....

- (ii) The power transferred from the battery to the motor depends on the ratio  $\frac{R}{r}$  as shown in the graph below.

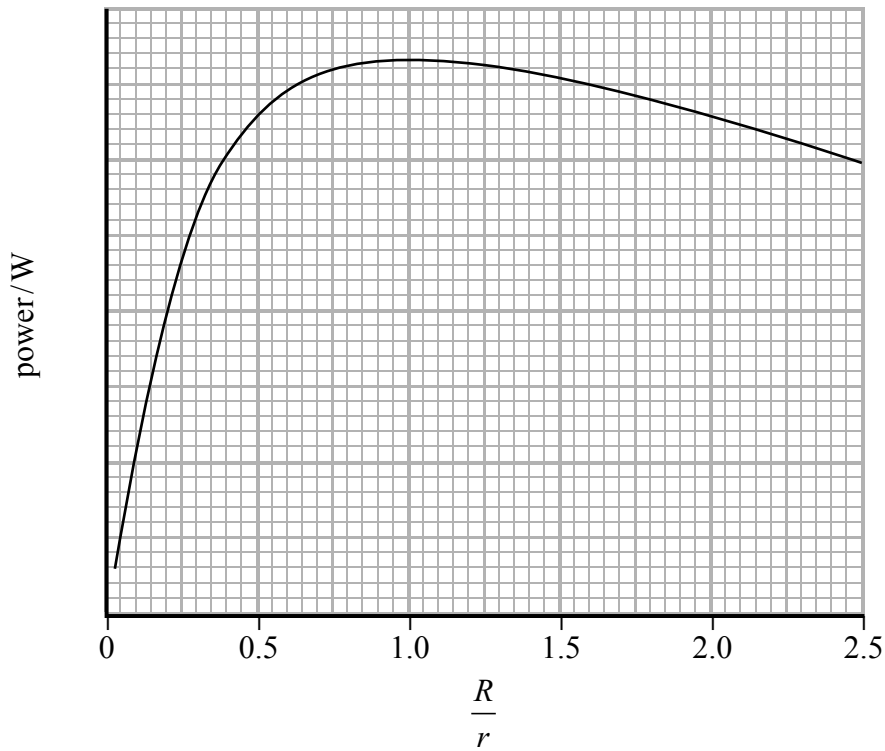

Determine whether maximum power is transferred to the motor.

(3)

.....

.....

.....

.....

.....

.....

.....

.....

**(Total for Question 16 = 10 marks)**

17 Pencil lead is a mixture of graphite and clay. The proportions of graphite and clay in the sample determine the hardness of the pencil lead, as well as the resistivity.

(a) The diagram shows two samples of pencil lead made from the same mixture of graphite and clay.

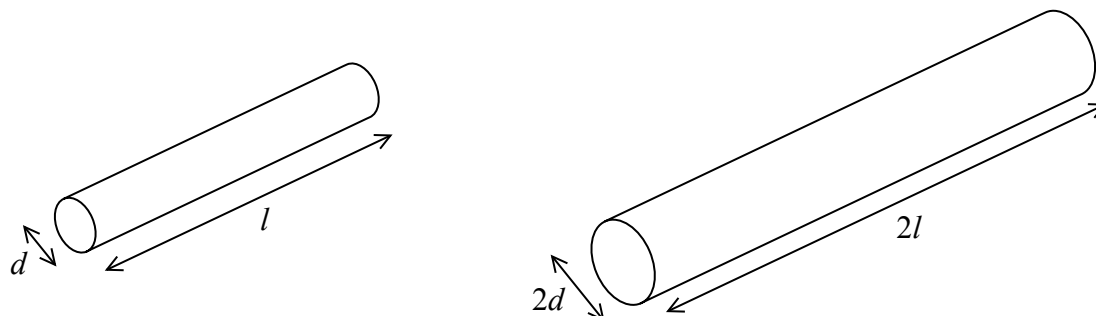

Sample A has a resistance  $R_A$ . Sample B has a resistance  $R_B$  and is twice the length and twice the diameter of sample A.

Calculate the ratio  $R_B/R_A$ .

(2)

.....  
.....  
.....

$$R_B/R_A = \text{.....}$$

(b) A graph supplied by the manufacturer shows that the resistance  $R$  of a pencil lead is inversely proportional to its cross-sectional area  $A$ .

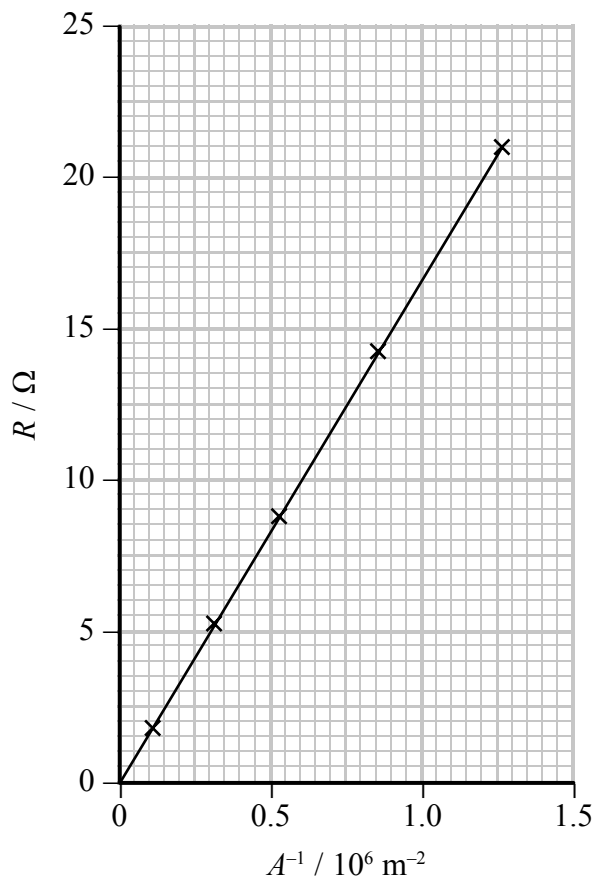

The resistivity of graphite is  $3 \times 10^{-5} \Omega \text{ m}$ . Use the graph to draw a conclusion about the effect of adding clay to graphite.

Length of pencil lead = 15.0 cm.

(4)

.....

.....

.....

.....

.....

.....

.....

.....

(c) Resistance can also be affected by temperature.

Explain why the resistance of a metal sample increases with an increase of temperature.

(3)

.....

.....

.....

.....

.....

.....

.....

.....

**(Total for Question 17 = 9 marks)**

---

**BLANK PAGE**  
**TURN OVER FOR QUESTION 18**

- 18 An electron beam tube can be used to demonstrate the deflection of electrons in a uniform magnetic field. The tube contains a very low pressure gas so that electron paths can be seen.

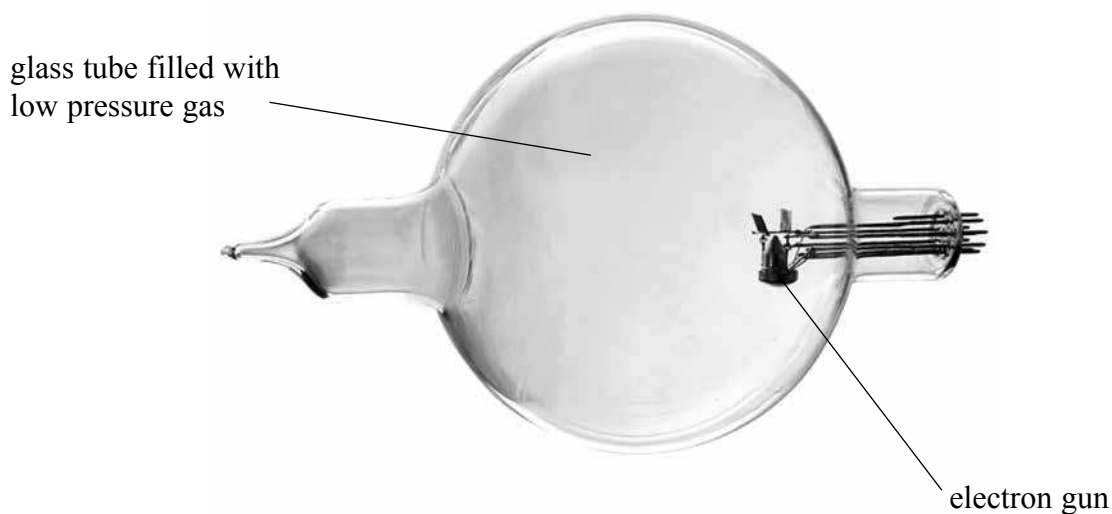

(Source: <http://www.klingereducational.com/images/products/thumbs/555571.jpg>)

Electrons are emitted from the electron gun travelling vertically upwards into a region of uniform horizontal magnetic flux density.

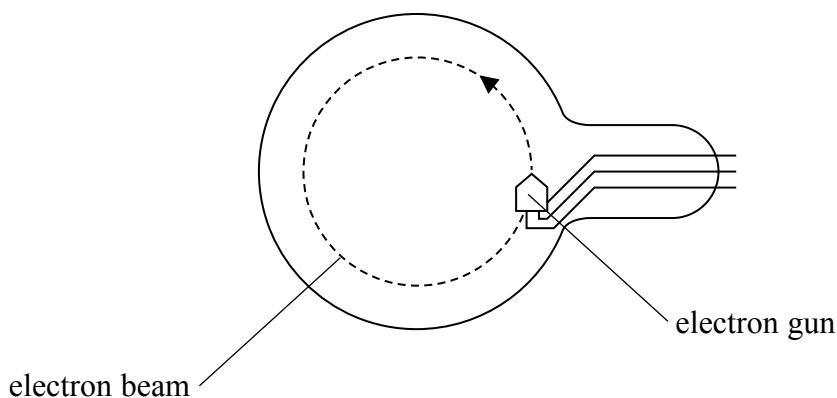

- (a) Show that the unit of magnetic flux density (Tesla) in SI base units is  $\text{kg A}^{-1} \text{s}^{-2}$ .

(2)

.....

.....

.....

.....



(b) Explain why the electrons follow a circular path.

(3)

.....

.....

.....

.....

.....

.....

(c) The magnetic flux density is varied while the speed of the electrons remains constant. The following data is obtained.

Radius/cm	Magnetic flux density/mT	
8.0	0.63	
9.5	0.52	
11.0	0.46	

Theory suggests that the radius of the electron path is inversely proportional to the magnetic flux density.

Analyse the data and comment on this suggestion, you may use the table to show any calculated values.

(4)

.....

.....

.....

.....

.....

.....

.....

.....

.....

.....

**(Total for Question 18 = 9 marks)**

**19** Some mobile phones have a capacitor touch screen made up of a sheet of glass with a thin metallic coating. The screen is charged and when it is touched some of the charge is transferred to the user. This causes a drop in electrical potential at the point where the screen is touched.

(a) A capacitor is charged by connecting it across a battery and then discharged through a resistor. In the case of the touch screen the user provides a discharge resistance of about  $900 \Omega$ .

Explain how the capacitor discharges.

(3)

.....

.....

.....

.....

.....

.....

.....

(b) A capacitor is discharged through a resistor of resistance  $900 \Omega$ . The graph shows how the charge on the capacitor decreases with time.

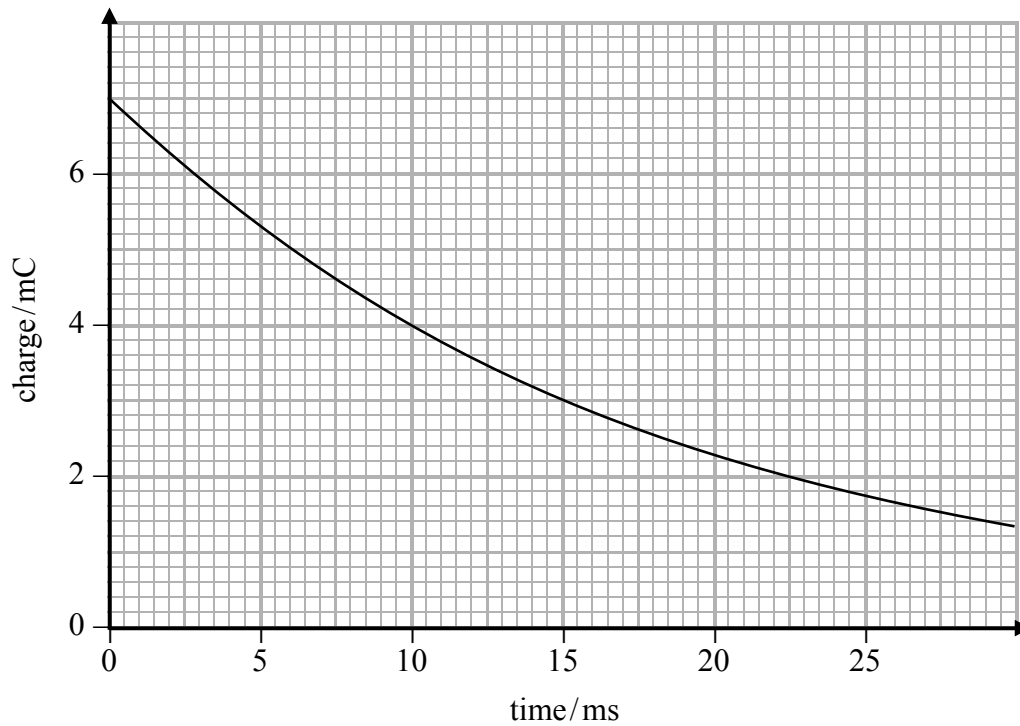

Calculate the capacitance of the capacitor.

(4)

.....

.....

.....

.....

.....

.....

.....

.....

Capacitance = .....

**(Total for Question 19 = 7 marks)**

- 20 The diagram shows the carriage of a rollercoaster about to enter a vertical loop of diameter 17.0 m. The carriage is initially at rest at a height  $\Delta h$  above the bottom of the loop.

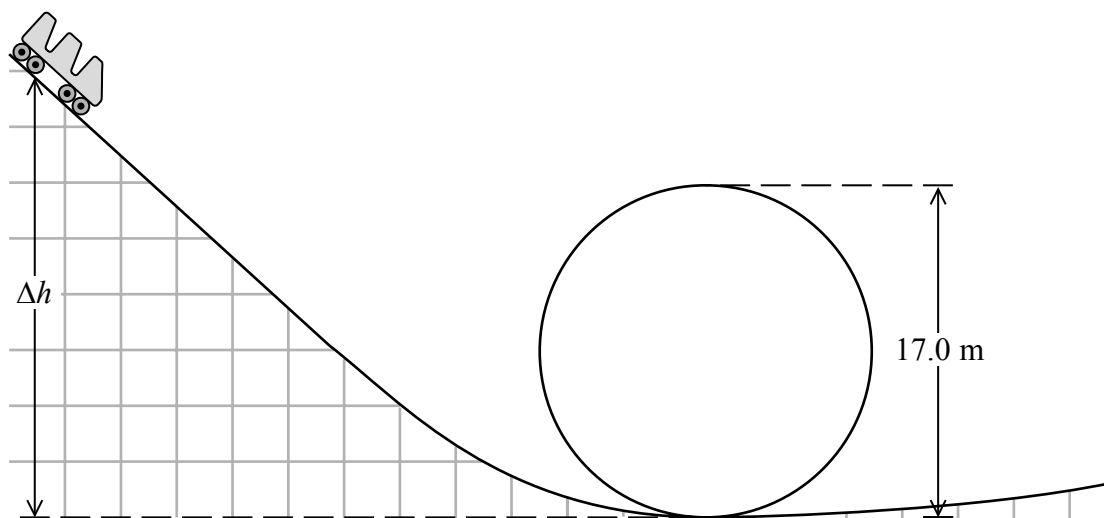

(a) (i) So that a passenger remains in contact with their seat at the top of the ride, show that the minimum speed of the car at the top of the loop is  $9.1 \text{ m s}^{-1}$ .

(3)

.....

.....

.....

.....

.....

.....

(ii) Calculate the minimum value of  $\Delta h$  that will enable the passenger to remain in contact with their seat at the top of the loop.

(3)

.....

.....

.....

.....

.....

$\Delta h =$  .....

(b) During one particular ride, the speed of a car at the bottom of the loop was  $22.5 \text{ m s}^{-1}$ .

(i) Calculate the acceleration of the passenger at the bottom of the loop as a multiple of  $g$ , the acceleration due to gravity.

(2)

.....

.....

.....

Acceleration = .....

- (ii) The maximum safe acceleration recommended for passengers is  $4g$ . Most loop-the-loop rollercoasters do not have a circular loop. Instead, the radius of curvature of the loop varies.

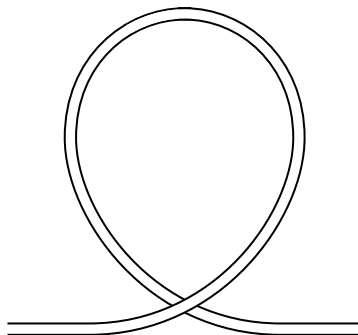

Explain why making the radius of the loop vary in this way enables the acceleration at the bottom of the loop to be less than  $4g$ .

(2)

.....

.....

.....

.....

**(Total for Question 20 = 10 marks)**

**TOTAL FOR PAPER = 90 MARKS**

Every effort has been made to contact copyright holders to obtain their permission for the use of copyright material. Pearson Education Ltd. will, if notified, be happy to rectify any errors or omissions and include any such rectifications in future editions.